



Choosing a mobile hoist

DLF Factsheet



Sponsored by **Hill-Rom** Enhancing Outcomes for Patients and Their Caregivers.™



lifting expectations



People come in all shapes, sizes and abilities, so you need an extensive range of tested products to be able to deal with all the challenges you face.

With the largest number of aluminium hoists in hospitals, special schools and community, Hill-Rom can offer you the best products at the best value for money, so call Hill-Rom today and

Let YOUR needs decide.

Phone: 01530 411000

Web: www.hill-rom.com/uk

Hill-Rom

Enhancing Outcomes for Patients and Their Caregivers™

© Disabled Living Foundation

All rights reserved. No reproduction or transmission of this publication may be made without written permission.

Inclusion (including any display advertising) does not indicate that any item has been recommended or tested. All information is provided without legal responsibility.

**Disabled Living Foundation
380-384 Harrow Road London W9 2HU**

Tel: (020) 7289 6111

Fax: (020) 7266 2922

Helpline: 0845 130 9177 -10am – 4pm

Textphone: (020) 7432 8009

Email: advice@dlf.org.uk

Website: www.dlf.org.uk

Reg. Charity No: 290069

VAT Reg. No: 226 9253 54

Contents

Choosing a mobile hoist

INTRODUCTION	4
WHERE TO GET HELP AND ADVICE	4
IS A MOBILE HOIST THE BEST OPTION	5
FACTORS TO CONSIDER WHEN CHOOSING A MOBILE HOIST	7
TYPES OF MOBILE HOISTS	8
FEATURES OF MOBILE HOISTS	10
SPECIAL FEATURES OF TOILETING/STANDING HOISTS	20
SPECIAL FEATURES OF MOBILE SEAT HOISTS	22
FACTORS TO CONSIDER WHEN CHOOSING A SLING	22
STANDARD TYPES OF SLINGS	24
ALTERNATIVE TYPES OF SUPPORT	30
MAINTENANCE AND SERVICING	31
USEFUL ORGANISATIONS	31

INTRODUCTION

Sometimes people require help to move from one position to another; yet any manual lifting and handling can place a severe strain on the person assisting, whether friend, family or professional. This often results in back pain or other injuries. By choosing appropriate equipment and using it effectively the risk of sustaining injury is greatly reduced and often the quality of life for all concerned is noticeably improved.

Some people complain that a hoist takes too long to use. Often this is because they are unfamiliar with the equipment, or because the equipment is unsuitable for the task. After a thorough reassessment to ensure the equipment is appropriate and with training and practice, the process of using a hoist usually becomes quicker and easier. Ultimately the aim of using equipment is to reduce the risk of the injury to the lowest level possible.

This factsheet aims to provide first stop information on the types of mobile hoists available and details about their various features.

For up-to-date product and supplier information, please contact the DLF equipment helpline, open daily from 10am to 4pm, tel: 0845 130 9177 (local rate) or textphone: 020 7432 8009 (standard rate).

Alternatively, write to our letter enquiry service via email at: advice@dlf.org.uk. Please provide as much detail as possible in order to help us send you a concise and informative reply; for example include

details about the difficulties you are experiencing and perhaps an idea of the type of equipment you are looking for.

WHERE TO GET HELP AND ADVICE

It is advisable to seek independent advice before buying equipment to help you make an informed choice about the equipment you plan to use. There may be alternative solutions to a difficulty, or the local authority may be able to provide a service that will help you.

Everyone, including a carer, has the right to ask the local authority for a community care assessment. Following the assessment, the local authority must decide what, if any, action is required.

If the person assessed does qualify for services, the local authority must draw up a care plan giving information on how the client's needs will be met in an effective, safe and cost efficient way. Solutions may include the provision of a service, equipment or a combination of both.

Where the assessment highlights risk of injury from moving and handling tasks, a manual handling risk assessment will be needed and an action plan drawn up to document how tasks should be managed, what equipment should be used and how many personal assistants are needed to carry out manoeuvres.

Provision of equipment has traditionally been through social services or the

community nursing service. Recent government initiatives have encouraged social and health services to combine resources to streamline equipment provision through a jointly run, integrated community equipment store (ICES).

Since April 2003 people have been able to ask for a direct payment of money instead of a council community care service. This includes the right to ask for money towards the cost of alternative equipment if this is preferred to the equipment offered by the local authority.

If a person's needs are few or simple, the local authority may not be able to provide direct help itself, but may be able to offer advice about where equipment can be bought locally, mail order suppliers or details of local support groups.

Contacting a Disabled Living Centre, which provides impartial advice and the option to try out equipment, is one of the best ways of finding out what is available. For the address of your nearest centre contact Assist UK (previously the Disabled Living Centres Council) (see useful organisations).

IS A MOBILE HOIST THE BEST OPTION



Before choosing a mobile hoist you need to consider all of the pros and cons and consider other possible options. This is why it is important to have a manual handling assessment so that every moving and handling situation is reviewed and safe solutions are found. Sometimes it is not possible to find one hoist or piece of equipment to suit every situation. Remember that, as well as meeting your transfer needs, the equipment must work effectively in the environment in which it is to be used, and your carers must be able to manage it.



The main alternatives to mobile hoists are overhead hoists. For more information on overhead hoists see our factsheet 'Choosing an overhead hoist'.



Sometimes there are simpler solutions to overcome moving and handling difficulties. Other options which might eliminate lifting tasks or enable the person to move independently/with limited assistance include changing the daily routine, re-arranging furniture, training in a technique or using small items of handling equipment in a safe way. Small handling equipment could include:

- low friction rollers or sheets - to enable people to turn or slide up and down in bed more easily;

- lifting poles to pull up on in order to partially sit or change position in bed;



- a handling belt for example when used in conjunction with a turntable. The person wears the handling belt and stands on the turntable to swivel transfer him/herself in a semi-stand position. The carer can help guide him/her around more easily by holding onto the belt;



- wooden transfer boards - for sliding from one surface to another;



- specifically designed wheeled equipment such as wheelchairs and sanitary chairs to move a person from one room to another.

FACTORS TO CONSIDER WHEN CHOOSING A MOBILE HOIST

The tasks

- Activities - is the hoist needed for one particular task, e.g. getting in and out of the bath; or is it needed for several, e.g. in and out of bed, on and off a chair? Remember to consider associated tasks, e.g. positioning slings, moving the hoist occupied and unoccupied.
- Use - is the hoist for independent use? Independent use is only possible with an overhead hoist. Will it need to reach the floor and/or lift high? Is it for one transfer in a set position or is flexibility required so that lifts can take place anywhere in the room?
- Frequency - is the hoist for emergency use only, e.g. lifting from the floor after a fall, or is it for frequent use, e.g. all transfers?

The home environment

- Space - is there enough space to manoeuvre the hoist and the person into the correct position? This is particularly relevant when the planned location for use includes bathrooms or toilets.
- Furniture - will a hoist base go around or under items such as beds, chairs, baths? Will the lifting height of the hoist be sufficient to lift the person clear of all surfaces? If the user has a pressure reducing mattress on top of the existing mattress, some hoists may not provide

sufficient lifting height to clear the mattress.

- Floor surfaces - are these suitable to move a mobile hoist across? Thick pile carpets and door thresholds can impede manoeuvres.

If these factors cause repeated, insoluble difficulties, consider an overhead hoist that runs on a straight or curved ceiling-fixed track.

- Storage - is there enough space to store the hoist? Some hoists will dismantle or fold up for storage or transportation.
- Charging - is there a convenient socket in the storage area for charging an electric hoist or is a removable battery needed so that the hoist is taken to be charged elsewhere?

Other environments

- Where - is the hoist purely for home use, or will it be used for getting in and out of the car or for taking on holiday?

The hoist user

- Type of disability - is the disability likely to remain stable for the foreseeable future, or is it likely to improve or deteriorate?
- Size - check that the hoist capacity and the size of the sling is suitable for the user's size and weight.

- Confidence - is the person confused or anxious? Will he/she feel more secure in a close fitting sling with less swing?

The carer

- Physical strength - consider the size and strength of the carer. It requires quite a lot of effort to turn and move a mobile hoist. Remember that hoists are designed as transferring, not transporting, aids - if the person needs to be carried over a distance, it is advisable to use an overhead track hoist or specifically designed wheeled equipment (e.g. wheelchairs or sanitary chairs).
- Ability to adapt - if the carer has moved the person in the same way for many years, it may take time and training to learn to use new equipment or new techniques.

TYPES OF MOBILE HOISTS

There are different types of mobile hoists including standard mobile hoists, toileting/standing hoists, and mobile seat hoists.

STANDARD MOBILE HOISTS

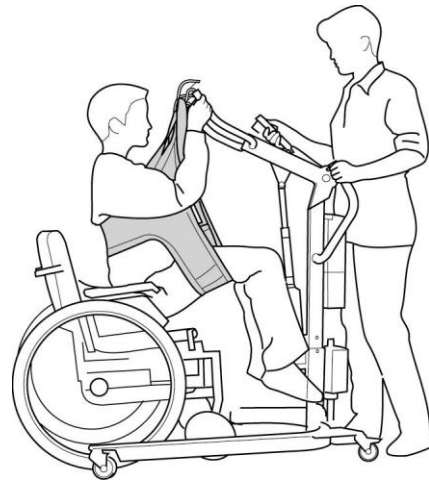

Standard mobile hoists have a mobile base and a sling lifting mechanism. They are used by a carer to lift and transfer a person from one surface to another. They cannot be used by the person independently. He/she is lifted in the sling. The many different slings available to suit different needs are described in more detail in section on 'Factors to consider when choosing a sling'.

Standard mobile hoists have four main parts:

- base or chassis with legs - wheeled, usually two with brakes;
- mast - the vertical support. This incorporates the lifting mechanism which is either mechanical (using a hydraulic pump or a winding handle) or battery powered. Choice will depend on individual need and preference. A detachable mast is useful for storage and for transporting the hoist in a car;

- boom - this extends from the mast to provide the reach across and has the spreader bar attached. Some booms have a peak or angle which helps with lifting from the floor and angles the boom away from the head allowing the person to swivel through 360° when suspended;
- spreader bar (also called a sling bar) - this provides the width to span the user's shoulders and the attachment points or hooks for the slings.

Standard mobile hoists can broadly be divided into two categories by size:

- small - the base is relatively small and narrow with a maximum lifting capacity of 100-160 kg (16-25 stone). These are generally more practical for domestic use;
- large - the base is relatively longer, wider and higher with a maximum lifting capacity of 160-300 kg (26-47 stone). These are more suitable in residential homes and hospitals where space is not such a problem and a greater range of lifting height and weight capacity is required.

TOILETING/STANDING HOISTS

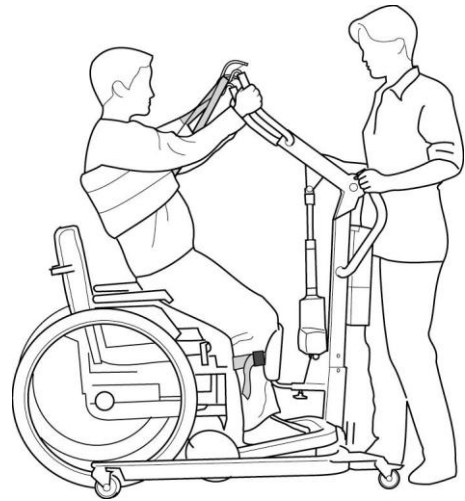

Manually operated or electrically powered toileting or standing hoists are available. They have a mobile base (often with a footrest) and a specifically designed sling arrangement. The person is hoisted into a supported standing position.

Most have a narrow sling that is positioned under the user's arms and sits halfway down the back - making it easy to access trousers, skirts and underwear which need to be adjusted before and after toileting. It is easier to use a standing hoist rather than a standard or overhead hoist for toileting, as long as the person has the necessary abilities. The users must be able to:

- * take some of their weight through their legs as the sling lifts them from a seated into a supported standing position;
- * brace their knees against a knee block to hold them securely whilst they are moved in the hoist;
- * have reasonable muscle tone around their shoulder girdle.

The person is lowered onto a toilet or a commode after the hoist has been carefully positioned and clothes have been adjusted.

If the person needs to be moved over a fairly long distance some standing hoists have an optional seat accessory. The person is lowered onto the seat before he/she is moved.

Some hoists have a dual function system with an interchangeable toileting boom and a standard sling boom.

Some standing hoists are quite large; their suitability for use in a domestic situation should be assessed before purchase.

MOBILE SEAT HOISTS



Seat hoists tend to be designed for one type of transfer, e.g. bathing. The seat provides less support than a sling and the person needs reasonable sitting balance. If someone is unable to sit, some models have a stretcher for the person to lie on - but these are big and bulky - usually unsuitable for home use.

The hoist is moved and operated by the carer(s), and so allows no degree of independence. Manual and powered versions are available.

FEATURES OF MOBILE HOISTS

THE HOIST CHASSIS

Length of chassis

The longer the chassis, the more difficult the hoist is to manoeuvre and the more floor space it will take up. However, it will provide greater stability, especially for high lifts and will give a tall person more leg room.

Width of chassis

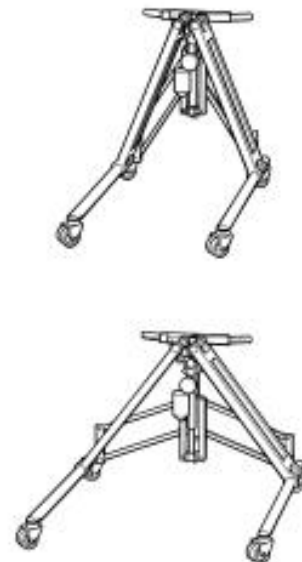

The width of some chassis can be adjusted which is useful as the chassis can be adapted to avoid obstacles, e.g. widened to position around a chair or narrowed to go through doorways. A

mobile hoist usually moves more easily when the chassis is at the standard width.

The width can be adjusted in several ways:

- by kicking out the legs using a foot;
- using a lever positioned next to the mast;
- using a foot paddle;
- by battery operated push button controls.

Some methods only enable the width of the front of the chassis to be increased, usually in one or two fixed stages, with the result that the width varies from front to back. Care should be taken when assessing the suitability of this type of hoist to go around an armchair, for example, as the width measurement given is for the widest point and the carer may be unable to push the hoist in close enough to position the person right back onto the seat of the chair.

Some hoists have parallel leg openings with the following benefits:

- * allow maximum parallel space between the legs which is especially advantageous when lifting from the floor;
- * enable lifting to and from the side of a wheelchair;
- facilitate access in a variety of settings.

Height of chassis



The chassis height determines whether or not the hoist can go under certain items of furniture, e.g. under a divan bed, in the cut-out space of a bath side.

Some manufacturers can fit alternative sized wheels to give a lower/higher chassis height.

Shape of chassis

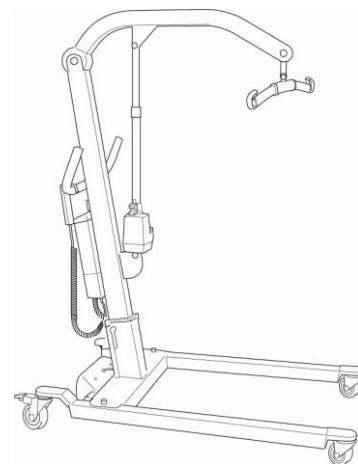

The majority of hoists have a U-shaped chassis.

Less common is a C-shaped chassis with the following benefits:

- the boom and spreader bar are brought in from one side; this can reduce the feeling that the spreader bar will touch the face of the person in the sling
- a person can be transferred from a chair into an adjacent bed without turning the hoist or the occupant. Once the person is comfortable in the sling, the hoist is pulled back and then pushed from the side towards and under the bed.

BRAKES, WHEELS AND CASTORS

Diameter of wheels/castors

- Small front wheels/castors - these keep the clearance height to a minimum to get the hoist underneath furniture such as divan beds.
- Large back wheels/castors - large castors are easier to push across floor surfaces, especially carpet and door thresholds.

Steering mechanism

A few hoists have a mechanism that helps the carer to push the hoist in a straight line. However, this is most useful in hospital situations when unoccupied hoists need to be pushed along corridors etc.

- 5th wheel (side position) - this wheel is placed on one or other side of the chassis. It helps to keep the hoist in a straight line, and provides a pivot point so that it can be turned on its own axis;

- 5th wheel (centrally placed) - the wheel is placed centrally under the mast and provides a pivot point so that it can be turned in a space which is double its length;
- steering device - a metal device which is flipped over the rear castors to lock them parallel to one another so that the hoist can travel backwards or forwards in a straight line. However, it is essential to flip back the device when going round corners as the carer may injure his/her back struggling to turn the hoist.

It should be remembered that mobile hoists are not designed to transport people over long distances. A ceiling mounted hoist or wheeled equipment, such as a wheelchair or sanichair, should be used instead.

Brakes

Brakes, which are fitted on most models of hoist, are not generally applied unless the hoist is parked, being assembled, being used on a slope, or if the person's legs are likely to go into extensor spasm, and cause the hoist to move unsafely.

It is usually preferable to leave the brakes off when lifting people. The hoist will tend to move towards them as they are lifted. If the brakes are on, the person is dragged towards the hoist. Also when lowering, if the spreader bar gets too near to the face, the hoist can be pulled back carefully.

Check that:

- the brakes are easy to operate
- it is easy to see whether the brakes are on or off. Castors that have button brakes look very similar in both the on and the off position.

LIFTING MECHANISM

The majority of hoists are better powered, a few are manually operated.

Manual mechanism (Hydraulic pump control)



The pumping action can be quite tiring for a carer and will require more effort as the angle between the mast and the boom increases. The person being lifted may find that the ride is more jerky than it would be if a winding handle is used. The following also need to be considered:

- handle height - this is sometimes positioned too low for the carer to adopt a comfortable posture to pump while standing; it is often easier to sit down and pump if there is a convenient bed or

chair nearby;

- handle position - this usually rotates so that the carer can use it from either side.

The rate at which the person can be lowered after lifting can be controlled by one of the following types of valve mechanism:

- screw thread valve - this requires fine control. However, once mastered, the speed of descent can be accurately controlled even if the carer leaves the controls to re-position or make the person comfortable;
- press button valve - pressure on the button needs to be maintained while the hoist descends. It descends at a fixed speed.

Manual mechanism (winding handle control)

Using a winding mechanism to lift a heavy person is harder work than using a pump action, but the person being lifted will have a smoother ride. The following needs to be considered:

- handle height - some winding handles are positioned on top of the mast and wind in a horizontal plane. The carer must therefore have good shoulder movement and strength, and may have to adopt a poor posture, especially if he/she is short in stature. Other handles are at a fixed height on the outer surface of the mast and are wound in a vertical plane.

A winding handle controls the speed of lift and descent accurately, and it is easy to stop and start precisely at the required height.

Battery powered mechanism (Button control)

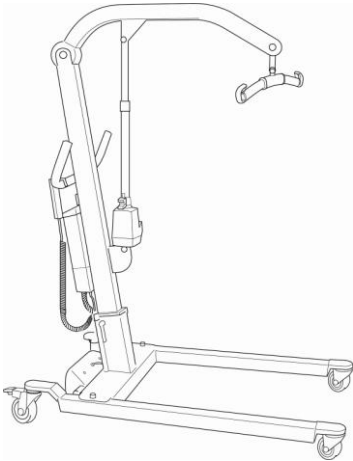

Much less effort is required to lift and lower a person if a battery powered hoist rather than a manual hoist is used, although the added weight of the batteries and motor may make the hoist more difficult to manoeuvre. Also consider the following:

- if the controls are on a flex or are remote, the person may be able to control the lift independently. This will enable the carer to have both hands free to assist with positioning;
- these hoists need regular charging so that access to a convenient power point is necessary if the batteries cannot be removed from the hoist;
- the speed of lifting and lowering the person cannot be varied, although some hoists are available with dual speeds.

LIFTING CAPABILITIES

Capacity of the hoist

Check that the weight of the person does not exceed the capacity that the hoist has been designed to work at safely. This safe working load will be marked somewhere on the hoist.

Shape and length of boom

A longer boom is useful for taller/larger people as it provides more leg room between the sling and the mast. However, it is worth remembering that if the boom is shorter, users can sit with both knees on one side of the mast. This can make it easier to position them, and will reduce the risk of knocking their knees.



A peaked or angled boom will help to lift the person up from the floor as it positions the spreader bar nearer to the floor, whilst at the same time allowing plenty of head room for the person in the sling.

Lifting height

The lifting range stated in the literature that comes with the hoist usually indicates the lowest and highest position of the spreader bar. Use these as a guide only. The actual lifting height will depend on the size of the person, and the size and style of the sling.

Some booms actually move up and down the mast, instead of angling from the top. These provide a good lifting range but, on some, the boom has to be manually adjusted to achieve the full range.

Lifting from the floor

Although most hoists will lift from the floor, some will need the following to carry out the task:

- a sling of a specific type or size - e.g. on some models it is advisable to use a sling that is one size larger than the size that the person would normally use;
- correct positioning of the user - some hoists require the head and shoulders of the person to be raised and supported either on pillows, against the back of an upturned dining chair or by a second carer.

The best types of slings to use are: a hammock or divided leg sling (see section on 'Standard types of slings'). Toileting or independent slings are unsafe to use to lift from the floor. (Most band slings are unsafe for transfers.)

BATTERIES AND CONTROLS

Batteries located on the mast



- These may cause an obstruction, depending on their position, the type of slings that are used, the size of the person and on the task being performed.
- The charging point is usually located at a convenient height so that the carer does not have to stoop.

Batteries located in the base

- These are less likely to cause an obstruction as they are usually located within the chassis frame.
- The chassis frame may be higher but, because the batteries are located at the back, this will seldom affect the ability to manoeuvre the hoist under furniture.
- The battery charging point is usually placed at a low level so that the carer has to stoop to connect the charger.

Charging batteries away from the hoist



Some hoists have removable batteries. They can be recharged away from the hoist.

- This is convenient if there is no plug near the hoist storage area.
- If two sets of batteries are provided, one battery can be on charge while the other is in use. When the batteries are changed over regularly the risk of losing power is greatly reduced.
- If there is only one battery, it is important to have an agreed charging routine, e.g. if not in use, on charge; or always on charge at night.

Low battery level indicator

The indicator is important, especially where charging is likely to be forgotten, or where sporadic use leads to confusion over the amount of charge left in the battery.

Some batteries have a visual low level indicator, and others a sound indicator. Some batteries have no low level indicator.

Number of lifts per charge

- Each manufacturer will provide an approximate indication as to how often the hoist batteries require recharging.
- Estimating the number of lifts is no alternative to using a low battery indicator since the amount of power used per lift will vary according to the person's weight, the height of the lift, as well as on other factors, such as the hoist being left switched on or the age of the battery.

Emergency lowering

If hoists are regularly checked and serviced it is unlikely they will become stuck. Unfortunately accidents can happen and it is wise to ensure an electric hoist has an emergency lowering system. This enables the person to be lowered if there is a failure in the hand set or electronics.

Emergency stop

The emergency stop button enables the carer to stop the raising or lowering action immediately if there is an emergency.

- This is often foot operated to enable a quicker reaction.
- Consider the position of the emergency stop button as it can be activated accidentally, especially when lifting someone from the floor if the emergency stop is on the chassis.

Emergency cut out

Some hoists have an emergency cut out feature, which will stop the lowering mechanism when the spreader bar meets any resistance, e.g. the person.

Hand held controls on a flex



- The person being lifted can operate these controls providing him/her with some element of independence and allowing the carer to have both hands free to assist.
- They may enable one carer, instead of two, to carry out the task as one or both hands are left free to assist or position the person.
- Magnetic controls can be quickly and easily placed anywhere on the mast when not in use.
- Controls should be clearly labelled; otherwise they are easily used upside-down, and the person will move in the wrong direction.

USING SLINGS ON A STANDARD MOBILE HOIST

Types of spreader bar

The size and type of spreader bar will influence the comfort of the person whilst he/she is being lifted. These features of the spreader bar should be considered.

- Points of suspension - the number and the spacing of the points of suspension on a spreader bar will affect the person's comfort.
- Suspension points that are close together can lead to the person feeling scrunched up, especially if he/she is heavily built



- Some companies can provide side hangers which will open out points of suspension.



- A few hoists have wishbone or Y-shaped spreader bars with three suspension points.
- Style of connection - an open hook on the end of the spreader bar is easier to use; a keyhole connection is more difficult to align and involves more effort but, once locked in place, is very safe.



- Tilting spreader bars - these can be used on some 4-point cross-shaped bars and wishbone or Y-shaped spreader bars and can help by bringing the point of attachment closer to the sling when lifting from an awkward position.
- A positioning handle located at the mast end of the spreader bar can be used to tilt or angle it so that the sling can be put

on more easily and the person held in a more upright position - he/she, for example can sit in a chair or on a toilet or lie back in a reclined position.

- Rotating through 360° - this is usually determined by the shape and angle of the boom. If the boom is angled upwards to form a peak, it usually allows the spreader bar to rotate through 360°. This increases the chance of manoeuvring the person into the correct position. However, peaked booms will bring people nearer to the mast as the boom rises, and it may therefore be necessary to rotate them so that their knees do not knock against the mast.
- Padded spreader bars - can be especially important if the spreader bar will be brought in close to the face.
- Distance from body and face - the wishbone or Y-shaped spreader bars come closer to the person's body and face than a coat hanger-style spreader bar.

Interchangeable spreader bars

Some hoists are sold as dual purpose hoists and have interchangeable components so that they can be used as standard sling hoists and toileting hoists.

Types of slings

Most companies have a good range of standard sling types and sizes, which may include:

- divided leg slings;
- hammock slings;
- toileting/access/ independence slings;
- band slings (are unsafe and rarely, if ever, used);
- amputee slings;
- walking/dressing slings

Most companies will produce slings to meet specific requirements; alternatively, some companies make made-to-measure slings for most types of hoist.

For details of these and other types of slings and supports that can be used with a mobile hoist, see section on 'Factors to consider when choosing a sling'.

STORING AND TRANSPORTING A HOIST

Chassis that dismantle/fold

Most small manual hoists dismantle and some fold. This is helpful if the hoists have to be transported, but it is often not practical to do this on a regular basis. The folded hoist or component parts are quite heavy and bulky to move around or lift.

Tools are needed to assemble most models that have been dismantled. Reassembled or unfolded hoists need checking to ensure they are secure before use.

The components of powered hoists are even heavier because of the weight of the batteries and the motors.

Several portable hoists are now advertised as lightweight. Usually they have less features than a conventional hoist, e.g. lower lifting range. It is important to check they are suitable for all the situations required.

SPECIAL FEATURES OF TOILETING/STANDING HOISTS

SINGLE VS DUAL PURPOSE HOISTS

Some of these hoists are exclusively for toileting purposes; others are part of a dual system hoist with an interchangeable toileting boom and a standard sling boom. The following points need to be considered:

- changing the booms can be time consuming;
- the booms are quite heavy and not always easy to slot in place as they need to be lifted above waist level; this can be especially difficult for carers who are short in stature or are not physically fit;

- there are often several components to each type of hoist - consider where they will be stored and whether they are likely to be constantly mislaid or mixed up, making the hoist unusable
- Compare the cost and the feasibility of storing a dual system hoist against that of two single purpose hoists.

TYPES OF SLING SUPPORT

Most models have the option of a standard padded sheepskin standing sling.

Padded sheepskin sling

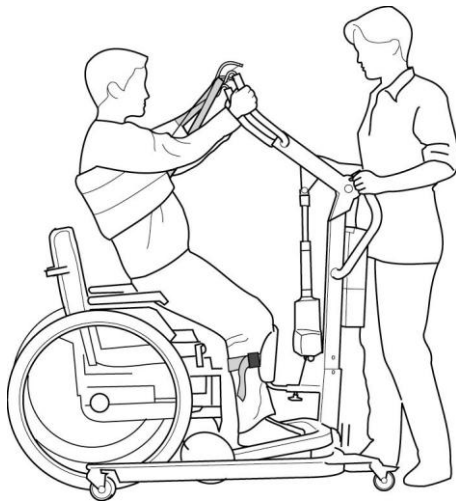

People **MUST** first be assessed by a therapist to establish whether or not this concept is suitable for them. It should only be used by people who can take the weight through their legs, who are without back or shoulder pain and who are co-operative and reliable. The capabilities of each person need to be individually assessed.

The sling is positioned under the arms and

sits halfway down the back.. People should be able to hold onto the handles on the boom to discourage them from raising their arms and sliding through. A knee pad provides a knee brace once in a standing position.

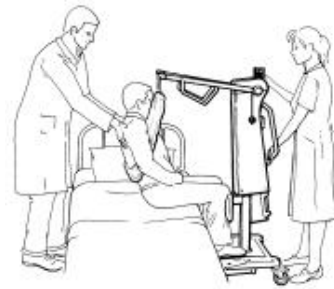

This type of sling will not suit everyone, especially those with weak and painful shoulders, or people who are confused who could move and slip through. The assessor should make sure that the person has the strength in his/her upper body to be lifted from this position. **ALWAYS** check with the occupational or physiotherapist if there is any doubt.

Wrap around sling

Some manufacturers can supply a more substantial sling that also wraps around the front of the user's chest, usually fastening with Velcro.

Four-point sling

This has an additional band support around the bottom connected by a central back panel. The sling attaches to the hoist at four points; the lower two can be removed during toileting in order to provide good access to clothes.

Divided leg sling

Similar to the four-point sling but the lower support wraps around the legs like a conventional divided leg sling. The leg sections can be removed for toileting purposes, leaving the top band in place.

SEAT ACCESSORY FOR TRANSPORT

This is a low slot-in seat that can be added if the person is being transferred any distance on the hoist. However, the following need to be considered:

- hoists should not be used as a method of transport over long distances. A ceiling mounted hoist or specially designed wheeled equipment, such as a wheelchair or sanichair which have much larger wheels in comparison to the castors of a hoist, should be used as they are much easier for the carer to push and manoeuvre;
- consider the dignity and comfort of the person. Which is more dignified, a wheelchair or a seat attached to a hoist?

COMMUNE PAN ACCESSORY



A removable commode pan can be used in conjunction with the seat for short transfers, moving the person from the bed or chair onto the seat with the commode pan underneath.

SPECIAL FEATURES OF MOBILE SEAT HOISTS

SEATS

These are most commonly used for bath transfers. The person remains on the seat and is lowered down into the bath.



Most have a seat with a commode aperture which can be used like a sanichair. Either, the person is wheeled over the toilet instead of transferring onto it, or it is used with a commode pan.

STRETCHERS

Some models have the option of a stretcher which enables the person to be moved and transferred into a bath in a semi-recumbent position. However, because of their size, they are usually unsuitable for use in a domestic setting.

DIRECTION OF TRAVEL

The person can either:

- face forwards while being moved, or
- face side ways. This makes possible transfers from the bed onto the seat and then straight into a bath without turning or swivelling.

OPTIONAL EXTRAS

The following may be available on some makes of seat hoist:

- commode pan - enables hoist to be used as a commode;.
- leg rest - enables a person to extend his/her legs while being transferred. The angle of the legs can be varied using different length straps;
- weighing scales - enables a person to be weighed while seated on the chair without transferring onto a set of scales.

FACTORS TO CONSIDER WHEN CHOOSING A SLING

The choice of hoist sling will depend on:

- the amount of support required;
- tasks which need to be undertaken;

- the comfort of the person being lifted;
- the ability of the person being lifted;
- the ability of the carer.
- the hoist used

Consider the following:

- sizes - slings always come in a range of sizes but, beware, corresponding sizes will vary from one company to another, in the way that shoe sizes often vary. It is very important that the person always uses the correct size of sling, even if this means changing it if he/she gains or loses weight;
- colour coding of slings - although many manufacturers colour code their slings for size, at the moment there is no consistency between the companies which can prove very confusing;
- loops (in the past, chains) on the slings - these are for positioning the person correctly in the sling, not for trying to make a sling that is too big or too small fit him/her. It may take several attempts to successfully position the person so that he/she is comfortable. Once this has been achieved, it is worth marking the loops that have been used to avoid wasting time in the future.
- amount of fabric - the more fabric there is in a sling, the more support it will offer and the larger the area over which the weight of the individual will be spread. Hence, hammock slings, which

have more fabric, distribute pressure over a larger area and are usually the most comfortable. This is particularly important for people who are susceptible to pain;

- points of suspension - the spread between the points of suspension for the sling will affect how the person is supported. The greater the spread between the suspension points the more open the sling will be. Although this may make the user feel more comfortable, he/she may feel less supported;
- sling fabrics and linings - a range of different sling fabrics and linings is available. Padded and lined leg pieces tend to be more comfortable and easier to put on. Mesh slings are easier to use in the bath;
- compatibility of slings - some slings are incompatible with some hoists. There is also the risk of wrongly attaching the slings. Some manufacturers stipulate that only their own slings can be used on their hoists. This is because of liability in the case of an accident. However, some companies will give permission for their slings to be used on compatible hoists manufactured by other companies. Always get the permission in writing from both the hoist and sling companies.
- specials - the majority of manufacturers will adapt and produce special slings to accommodate the person's specific needs and some companies produce made-to-measure slings for most makes

of hoist. However, a sling can take up to eight weeks to make and can be expensive. In addition, there is no guarantee that it will solve the problem, as there is no way of trying it before it is made. Always ensure that there is no off-the-shelf sling that is suitable before ordering a special. Try out different styles and sizes.

Applying the sling

When putting on slings in bed, if possible raise the height of the bed to a position that is comfortable for the carer to work at.

When putting on slings in a wheelchair, commode or armchair, remember the following:

- leave the leg/foot rests on the chair as this makes it easier to get the slings under the thighs;
- to get the slings under the thighs, the carer should squat in front of the chair and put the person's foot on his/her thigh so that there is enough room under it to manoeuvre the sling, in this way the person's leg is supported and the carer's back is in a good position.

The carer should NOT stand up and bend over to lift one or both of the legs of the person to position the sling underneath.

When trying out new slings remember that It may take a few attempts to find the most comfortable position, and that the first sling that is tried may not be the correct size and/or shape.

STANDARD TYPES OF SLINGS

DIVIDED LEG SLINGS

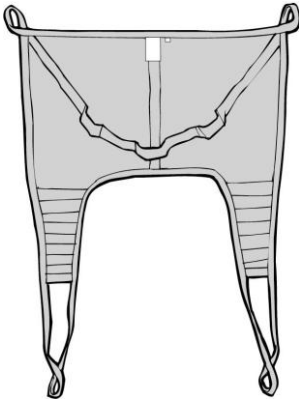

A divided leg sling is a U-shaped piece of fabric available with or without head support. This sling can be used in the following ways:

- with a leg band under each leg and then crossed in the middle. This provides the person with a reasonable amount of dignity



- with a leg band under each leg and not crossed. This allows the legs to be kept apart for toileting and washing. There is a risk of the legs swinging apart with a consequent loss of dignity;

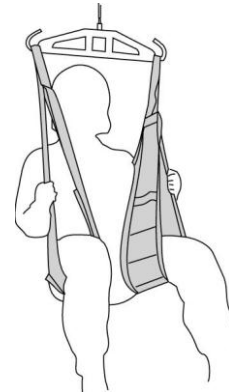

- with both leg bands under both legs. Sometimes this is a more comfortable for the person in the sling. There is a greater risk he/she will slip out and this position should be used only after a careful assessment.



Advantages

- Can be put on and taken off easily in most positions: sitting, lying, on the floor etc.

- The person may be able to put the sling on independently.
- Provides good access for toileting/washing.
- Provides a choice of leg positions.
- With the leg bands in the crossed position and with the correct sized sling, it is virtually impossible to fall out.
- No user co-operation is required.

Disadvantages

- Need to remove clothes for toileting before hoisting which may involve first transferring onto a bed.
- Leg pieces may be uncomfortable (see below).
- With both leg bands under both legs, the person may, if he/she goes into extensor spasm, slide out of the sling.

Comfort

- Adequate support will not be provided if the leg pieces are too narrow, or they are not positioned under the mid thighs.
- Padded or lined leg pieces are less likely to crumple when used in the crossed position and will therefore be more comfortable.
- Some companies have a loop system which holds the leg pieces together without having to cross them over. This may help to reduce crumpling.

TOILETING/ACCESS/INDEPENDENCE SLINGS

Access or toileting slings fit between the legs and around the user's chest.

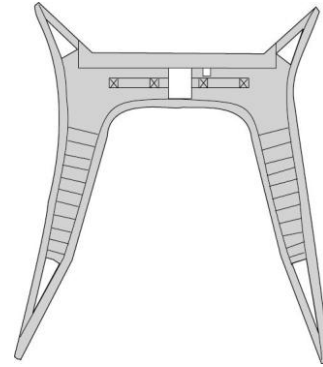

These slings leave a large area clear around the hips so that clothing can be adjusted for toileting. This style does not offer as much support as other slings and is therefore only suitable for a few hoist users.

Advantages

- It is easy to put on and take off.
- The person may be able to put the sling on independently.
- Provides good access for toileting/washing.

Disadvantages

- It does not provide enough support for everyone. Those with little or no muscle tone in their legs may slip through the sling.
- Although it is available with head support, most people who do not have head control will rarely have the

necessary trunk control and the sling will not be suitable for them. Some degree of sitting balance is essential.

- Only suitable from a sitting to sitting position. Unsuitable from a lying position. Never use to lift someone from the floor.
- If the user's arms are raised unexpectedly, he/she could slip through the sling. Therefore co-operation from the user is required.

Comfort

- Padded or lined leg pieces are more comfortable and do not crumple.
- A loop system to keep the legs together rather than crossing over the leg pieces is more comfortable and easier for the carer.
- The leg pieces should be positioned under the mid-thigh so that adequate support is provided.

HAMMOCK SLINGS

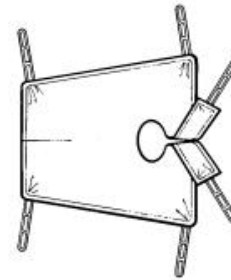
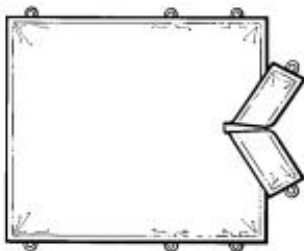

This type of is usually a rectangular piece of fabric, with or without a commode aperture.

The person is rolled onto the sling in a lying position. If the sling is to be sat on for long periods of time, the fabric from which

It is made should be considered carefully. Polyester netting may be suitable.

Advantages

- This sling is safe for most hoist users.
- Many people find them very comfortable as the body weight is supported over a large area of material and therefore pressure areas are unlikely to form.
- No user co-operation is required.
- It provides very good support.

Disadvantages

- The sling is not easy to take on and off. The person usually needs to be rolled onto it in a lying position.
- The person is not able to put the sling on independently.
- Provides little or no access for toileting/washing.

- When a commode aperture is present, it may be difficult to line it up accurately.
- If the person is being transferred into a chair or wheelchair, he/she may have to remain sitting on the sling, as it will be difficult to re-position it when the time comes to get out of the chair.
- If being used for bathing, clothes must be removed before hoisting and then the user will have to return to the bed to get dressed again.

Comfort

- Can be comfortable for people with widespread pain, for example those with rheumatoid arthritis, as it provides full body support.
- If used in conjunction with side hangers, the person will be less scrunched up and therefore even more comfortable.

BAND SLINGS

Band slings consist of two separate bands of material - one under the thighs and the other behind the back. Many accidents have occurred when band slings have been used.

- These are unsafe and should not be used. They have now been replaced by more adaptable and supportive slings. The comparable sling is the independent or toileting sling.

SLINGS FOR USE WITH A TILTING SPREADER BAR

These spreader bars are wishbone shaped. The slings have no choice of loops, as positioning is achieved by using the moveable spreader bar which will enable positions from lying to sitting to be achieved.

Advantages

- It is easy for users to reposition themselves within the sling.

Disadvantages

- This type of hoist will not accommodate a hammock-type sling.
- Sling design means they cannot be used with other manufacturers' hoists.
- If this type of hoist is being used to lift someone from the floor, the carer may need to use a sling which is one size larger than that generally used, since the spreader bar does not reach low enough for the sling to be attached easily.

Comfort

- It is generally accepted to be a very comfortable hoist and sling, due to the ease of positioning.

AMPUTEE SLINGS

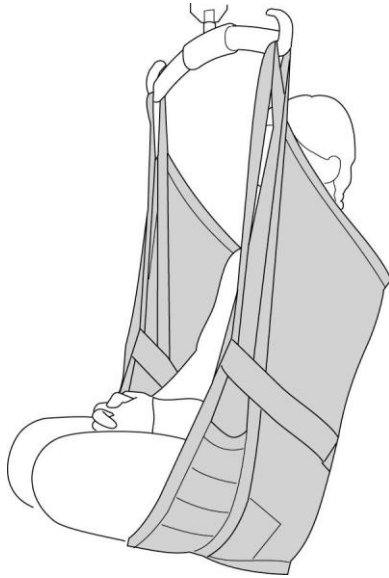

Although many companies sell specially designed amputee slings, a one-piece or hammock sling used on a conventional spreader bar may serve just as well. However, the sling may need to be supplied with extra long straps at the front edge if the person is to achieve an upright sitting position.

STANDING / WALKING HARNESS/ DRESSING SLINGS

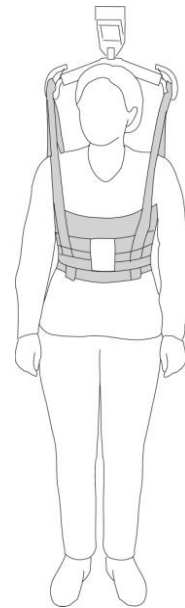

It is possible to use these slings with some of the larger portable hoists and many of the overhead track hoists to assist with walking, standing or dressing. They support the trunk area of the body. The fastening mechanism allows a degree of adjustment and on some makes of harness the straps are self-adjusting. This style of sling may offer a solution to standing up from a chair, especially one with a deep seat.

Some walking harnesses have the addition of leg straps to distribute body weight better.

LIFT PANTS



Shaped sling that runs between the user's legs to provide support in an upright, standing position. Primarily used for confidence building when walking.

STRETCHER SLINGS



These are used to transport a person in a horizontal position. Some stretcher slings are made of fabric, others are solid. If they are to be used in an X-ray situation, check that they are X-ray translucent. The solid stretchers are usually composed of several components which makes transferring the person easier.

DISPOSABLE SLINGS

These are made of a very strong, disposable material and are used in environments where the sharing of slings would increase the risk of infection. A disposable sling is used for a single person for the duration of his/her stay, then thrown away.

ALTERNATIVE TYPES OF SUPPORT

Some manufacturers of hoists offer a four-point suspension frame as an accessory for their hoists which will provide more space within the sling.

Christina Gordon Harness



This is a front fitting harness that clips onto a square spreader bar and can be used on many makes of overhead hoist and some mobile hoists.

Advantages

- A four-point suspension spreader bar can be more comfortable as the person is less scrunched up.
- The four-point frame ensures that the head and shoulders are lifted first.
- It provides good access for washing and toileting.
- It can be put on in most positions: sitting, lying etc.
- The person may be able to fit the harness independently.

Disadvantages

- It cannot be used with all mobile hoists because of the clearance height needed.
- It is more expensive than standard slings.

Comfort

- The leg pieces should be positioned under the mid-thighs.
- Vest-like harness provides stability.

HANDI-MOVE FRAME

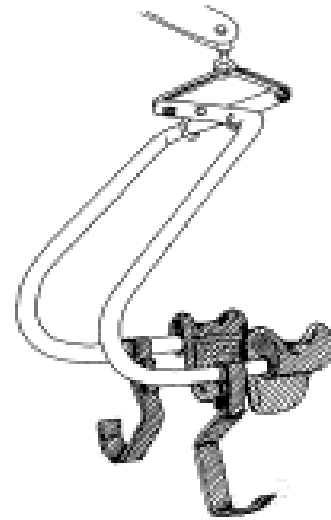

This is an adjustable metal frame with thigh stirrups and cup-shaped body supports to provide a scissor-like gripping action around the chest. One size of frame will adjust to all sizes. The person will require head control to use this system.

Advantages

- It is easy to put on, both independently or with help from a carer.
- It provides good access for washing and toileting.
- It is easy to keep clean.
- The person does not need any sitting balance, shoulder or muscle strength.

Disadvantages

- Not everyone will find the chest or leg supports comfortable.

MAINTENANCE AND SERVICING

It is important that equipment such as hoists is maintained regularly to keep it in good working order.

Hoist users need to ensure daily checks are completed as recommended in the instructions for use. In the domestic situation a relative carer, formal carer, a visiting health worker or the user might complete this.

The owner of the hoist has the duty to ensure faults are repaired. It is essential to keep a note of who is the owner and to whom faults should be reported. It is advisable to keep a written record of the date and type of faults reported and of the repairs carried out. Formal checks and servicing also need recording.

It is recommended in the British Standard for mobile hoists that they should be serviced by competent personnel at regular intervals of not more than 12 months.

Ensure that responsibility for this is established at the time of provision - especially if the funding has come from several sources.

The Lifting Operation and Lifting Equipment Regulations 1998 (part of Health and Safety at Work Legislation) places a duty on the employer to ensure equipment used by the employee for lifting people is also checked every six months by a competent person if the equipment is exposed to conditions liable to result in a dangerous

situation.

It is wise to complete a six monthly check as, over time, the person's abilities and his/her size may vary, carers change and the environmental demands differ.

Sometimes it is necessary to have a more frequent check.

USEFUL ORGANISATIONS

ASSIST UK (formerly DLCC)
Regional Disabled Living Centre
Redbank House 4
St Chads Street
Manchester M8 8QA
Tel: 0870 770 2866
Fax: 0870 770 2867
Email: general.info@assist-uk.org
Website: www.assist-uk.org

Back Care
16 Elmtree Road
Teddington
Middlesex
TW11 8ST
Tel: 020 8977 5474
Fax: 020 8943 5318
Email: info@backcare.org.uk
Website: www.backcare.org.uk

College of Occupational Therapists
106-114 Borough High Street
Southwark
London SE1 1LB
Tel: 020 7357 6480
Fax: 020 7450 2299
Email: cot@cot.co.uk
Website: www.cot.co.uk

Royal College of Nursing
20 Cavendish Square
London W1M 0AB
Tel: 020 7409 3333
Fax: 020 7647 3435
Website: www.rcn.org.uk



DLF online

The majority of DLF's advice is now online. If you would like advice and support to get online or information on local courses about getting online please visit one of the following websites.

Age UK

<http://www.ageuk.org.uk/work-and-learning/technology-and-internet/>

Call **0800 169 8787**

BBC Webwise

<http://www.bbc.co.uk/webwise/>

Call **08000 150 950**

Digital Unite

<http://learning.digitalunite.com/category/using-the-internet/>

Call **0800 228 9272** Or you can write to them

Digital Unite Limited, Unit 2B Poles Copse, Poles Lane, Otterbourne, Winchester, SO21 2DZ

Go On

<http://www.go-on.co.uk/>

Call 0800 77 1234

UK online centres, The Quadrant, 99 Parkway Avenue, Parkway Business Park, Sheffield, S9 4WG

UK Online Centre

<http://www.ukonlinecentres.com/>

