



# Choosing a standard self propelled wheelchair

---

DLF Factsheet

**© Disabled Living Foundation**  
All rights reserved. No reproduction or transmission of this publication may be made without written permission. Inclusion (including any display advertising) does not indicate that any item has been recommended or tested. All information is provided without legal responsibility.

**Disabled Living Foundation**  
380-384 Harrow Road London W9 2HU

**Tel: (020) 7289 6111**  
**Fax: (020) 7266 2922**  
**Helpline: 0845 130 9177 – 10am – 4pm**  
**Textphone: 020 7432 8009**  
**Email: [advice@dlf.org](mailto:advice@dlf.org)**  
**Website: [www.dlf.org.uk](http://www.dlf.org.uk)**  
**Reg. Charity No: 290069**  
**VAT Reg. No: 226 9253 54**

---

# Contents

## Choosing a standard self propelled wheelchair

INTRODUCTION	4
SOURCES OF SUPPLY - WHO CAN HELP?	19
STANDARD SELF-PROPELLED WHEELCHAIRS	12
SELF PROPELLED WHEELCHAIRS WITH SPECIAL FEATURES	14
GENERAL INFORMATION	18
FURTHER READING	23
USEFUL ORGANISATIONS	23

# INTRODUCTION

A large number of different types of wheelchair are available on the market, for the simple reason that chairs are required to fulfil a number of different functions.

There are three different types of wheelchair: self-propelled, electric, and attendant-propelled. This factsheet concentrates on the first category but other types of chair are referred to so that the user can make an informed choice from the wide range available. The terms standard user and active user are frequently referred to as types of wheelchair. Active user chairs are those which can be set up quite specifically to meet the needs of the user in many different ways. This makes a big difference to the ease of use of a chair and is of great benefit to someone who relies on a wheelchair day in and day out. Chairs which do not have this level of adjustability are referred to as standard wheelchairs.

The first section considers the user's basic needs in relation to the features of self-propelled wheelchairs, while the second contains specific advice on the different types of self-propelled chairs and the options that will influence the user's choice of one model as opposed to another. This is followed by a section on self-propelled chairs with special features and notes on general 'using' issues such as maintenance. The final section deals with the various ways in which wheelchairs and their accessories can be provided depending on the user's particular circumstances. Self-propelled chairs, as their name implies, are propelled by the

user and are primarily for daily living including sport. In general, these chairs are lighter, more easily transportable and easier to maintain than electric chairs, although many people, and not only those who are unable to propel themselves, find electric wheelchairs or scooters more convenient if, for instance, they find it difficult to transfer into a car to go to the local shops. (For further details, see DLF factsheet 'Choosing an electric wheelchair' or 'Choosing a scooter or buggy'.)

If a self-propelled model proves unsuitable, then an attendant-propelled wheelchair could be considered. (For further details, see DLF factsheet 'Choosing an attendant propelled wheelchair'.)

Any chair with large rear wheels is easier to push, especially up and down kerbs, than an 'attendant propelled' chair with the small rear wheels. Therefore, users may buy, or be issued with, a standard self-propelled chair solely to be pushed around by someone else.

The lightest and most manoeuvrable wheelchairs on the market are the high performance chairs. They have large rear wheels that can be positioned further forward than those on a standard wheelchair. As a result of this modification, weight is redistributed so that less effort is needed to propel or push this type of chair. The reduced weight is also an advantage when the chair has to be transported, and the user might choose an active user chair in preference to a

standard self-propelled chair or an electric vehicle if the wheelchair has to be carried frequently. (For further details on high performance chairs, see DLF factsheet 'Choosing active user wheelchairs'.)

Active user wheelchairs can be expensive, and users who cannot afford or justify the cost of such a chair often opt for a standard manual chair. This booklet discusses those features of any wheelchair that increase its manoeuvrability, especially if it is going to be pushed outside. Some of the features are only available on active user chairs, others are beginning to be incorporated onto the standard models and can be found if the user 'shops around', e.g. some have their large rear wheels fixed further forward so that the weight is redistributed as mentioned above.

Always consider carefully before choosing a specific model, and ensure that the user has tried the wheelchair around the house and over local routes so that difficulties can be sorted out.

For up-to-date product and supplier information, please contact our equipment helpline, open daily from 10am-4pm, Tel 0845 130 9177 (local rate) or textphone 0207 432 8009 (standard rate).

Alternatively, you may wish to email or send a letter to our advice service. If you email or write, please provide as much detail as possible in order to help us send you a concise and accurate reply. For example, send us details of the difficulties

you are experiencing and perhaps an idea of the type of equipment you are looking for.

## **SOURCES OF SUPPLY - WHO CAN HELP?**

Wheelchairs and related equipment are provided through a number of different channels depending upon its primary purpose - especially whether it is for permanent loan or temporary use.

### **PERMANENT LOAN**

#### **Health and local authority provision**

Most statutory provision of wheelchairs is carried out by, or through, the wheelchair service. This is part of the health authority or hospital trust and is organised on a district-wide basis. Often based at the local district hospital, it is able to provide wide range of wheelchairs and cushions.

### **Referral**

Referral to the wheelchair service can be made by a range of professionals including therapists, nurses, and doctors. The prescription, however, needs to be undertaken by trained prescribers, i.e. they are accredited or recognised therapists or sometimes specialised nurses, hospital consultants, or GPs.

## Eligibility criteria

Apart from the basic criterion of limited walking ability, a number of other criteria are employed for obtaining a wheelchair. These, however, may vary between centres and at different times of the year.

## Range of equipment available

A wide range of equipment is available. A standard range of manual wheelchairs is obtainable from the wheelchair services. However, active user models, adapted wheelchairs, and 'bespoke' wheelchairs can be provided. Their availability may be affected by the state of the budget.

Similarly, standard cushions, special cushions and special seating are available. These require varying levels of assessment and authorisation. Seating systems may be provided by special seating clinics.

Since April 1996, powered indoor/outdoor wheelchairs have been provided for severely disabled people who meet the local eligibility criteria. These usually include the user being unable to propel a manual wheelchair, benefiting from an improved quality of life, and being able to control the chair safely. Powered attendant propelled chairs can also be provided if it is hard for the carer to push the user out of doors.

The wheelchair service operates a voucher scheme. This is a cash equivalent based

on the user's level of need. This can then be added to if the user wants a more expensive manual wheelchair.

## Education service

Equipment that can be funded through the education service should be needed primarily for education and includes access devices, such as ramps, adaptations to school premises, wheelchairs for mobility at school, as well as other writing, speech and computer equipment.

It could be equipment for an individual, such as a wheelchair or cushion, or equipment for common use around a school, e.g. ramps, platform lifts and stairlifts. In theory, the equipment should be used for educational purposes only.

## Employment service

Employment equipment and adaptations are defined as any equipment which is primarily for the purposes of meeting an employment need. This could include wheelchairs and cushions, ramps, short rise lifts and stairlifts.

Employment equipment and adaptations are provided through:

- the Disability Service Teams (DSTs) which operate within the Employment service (ES) in England, Scotland and Wales;

- the Disability Employment Advisers (DEAs) who work from local job centres and who, as well as providing a wide range of advice and help to people who have particular difficulties in finding or keeping work because of a disability, can also advise on how to obtain equipment for employment;
- the Access to Work (AtW) advisers who have specialist knowledge of the AtW programme which provides support to disabled people and their employers to overcome work related obstacles resulting from disability.

Help provided by the AtW scheme will depend on the needs of the individual and may take the form of special aids or equipment, adaptations to premises and equipment, communication support at work, assistance for fares to work, vehicle adaptations, personal reader service, support workers or any other help that may be relevant. The amount available is dependent on the help required. For people who have been in a job less than six weeks or about to start work, AtW will cover 100% of approved costs. For those who have been in their jobs for six weeks or more when they apply it will cover 80% of costs up to £10,000 and all costs over £10,000.

Contact your Job Centre or Job Centreplus office to make an appointment with the DEA. The Job Centreplus Disability Service team can put you in contact with the AtW Adviser.

## **PURCHASE OF EQUIPMENT**

### **Private purchase**

Private purchase might be preferred either because a person wishes to buy privately, or because the statutory services are unable to provide the item required.

### **Second-hand equipment**

Some second-hand equipment, especially wheelchairs, scooters and buggies, can be bought through commercial suppliers. Although the equipment tends to be more expensive than it would be if bought from a private individual, usually it has been overhauled and may carry a guarantee of up to 12 months.

Many disability organisations publish journals which contain advertisements for second-hand equipment. DLF has a factsheet which lists these (Sources of Second-Hand Equipment)

### **Funding from charitable sources**

The most complete list of the charities and organisations that will give grants and funding is in a directory entitled *A guide to grants for individuals in need* published by the Directory for Social Change.

A specific charity that provides funding for children's wheelchairs is called Whizzkidz.

## **SELECTING THE APPROPRIATE EQUIPMENT**

Before buying, try to see and try out the equipment. There are about 40 Disabled Living Centres around the country which have a wide range of equipment on display. All can give advice and information on wheelchairs and related equipment. For details of your nearest centre, contact Disabled Living Centres Council (see useful organisations).

Wheelchairs can be bought through the major manufacturers and local suppliers. It is best to try them out in a home setting to ensure that there are no hidden problems such as narrow doors or impassable steps.

Check whether the supplier belongs to the British Healthcare Trades Association - Wheelchair Distributors section. The association produces a code of good practice to which their members are expected to conform. Before purchase, the following should be checked:

- what is the delivery time?
- will the wheelchair arrive readily assembled?
- what guarantee is available?
- what after-care service is offered?
- how much is the call out charge?

- will spare parts be brought to the home?
- if the chair has to be taken away for repairs will a 'loan chair' be offered?
- does the manufacturer offer insurance schemes?

## **SHORT TERM LOAN/HIRE OF WHEELCHAIRS**

### **Statutory provision**

If the wheelchair is needed only temporarily, it may be supplied through a number of channels. Three months is probably the average maximum loan period and the chairs are usually loaned free of charge. They may be obtained through the following sources:

- hospital in-patient loan;
- hospital discharge wheelchair loan;
- hospital wheelchair pools;
- community nursing services;
- District Wheelchair Service.

## **VOLUNTARY ORGANISATION PROVISION**

Organisations such as the Red Cross sometimes loan manual wheelchairs on a

temporary basis from local branches. The deposit and hire charges may vary.

## PRIVATE HIRE

A number of private hire firms make daily/weekly/monthly hire charges which may vary in amount and in the conditions attached.

## WHAT DOES THE USER NEED? A stable seating base

Even though the user may not need to propel the wheelchair over any great distance, a stable seating base will enable him/her to carry out daily living tasks as independently as possible. It is much easier to eat, use a communication aid and transfer to and from the wheelchair from a stable symmetrical seating base.

A small number of people who use wheelchairs may never fully develop the ability to sit unaided. Others may gradually lose the ability, perhaps as the result of a progressive disabling condition. For people with mild to moderate seating difficulties, the correct size and positioning of the wheelchair seat unit components may be all that is needed to provide them with a stable seating base. Users with complex needs may require a specialised seating system.

The following factors need to be considered.

## Seat size

Maximum stability will be achieved if the user's body fits comfortably into the chair seat. If his/her weight is evenly distributed over the largest area possible, this will also provide pressure relief.

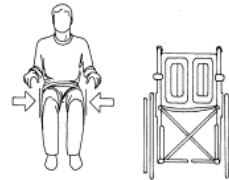

If the seat is too wide, users often sit asymmetrically (lean more to one side) in order to feel supported. If the seat is too narrow, it will be uncomfortable and increase the risk of pressure sores.

If the seat is too short, the full length of the thighs will not be supported and too much pressure will be transferred onto the buttocks.

If the seat is too long, it may cause undue pressure behind the knee, and the user may not get adequate support from the backrest.

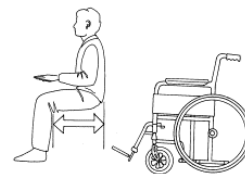

Chairs are available with a range of seat depths and widths.

## Shape and angle of seat

The seat needs to be level. A sagging wheelchair seat canvas will cause users to sit asymmetrically or with their thighs and knees rolled together. This may cause undue pressure and 'shearing' - the term used when the outer layer of skin is pulled in a certain direction while distorting and restricting the underlying blood vessels. This may lead to pressure sores.

When maintaining a good seating posture the angle between the thighs and the trunk is critical as it determines the stability of the pelvis. An angle of 90° is considered best for most people for daily activities. Using a contoured or ramped seat or cushion, ie very slightly lower at the back to accommodate the shape of the buttocks, is the easiest way of achieving this.

All wheelchair users should be sitting on a cushion which has been chosen at the same time as the wheelchair and fits its seat. Full-time wheelchair users will probably need a pressure relief cushion; occasional users may only need one for comfort. (For further details, see DLF factsheet 'Choosing a wheelchair cushion'.)

To fully stabilise the lower body, the foot support needs to be considered next.

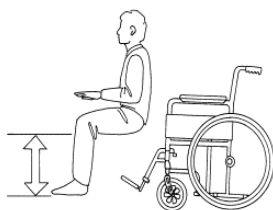

## Footrest length

If an angle of 90° between the user's thighs and pelvis is achieved, most people will be comfortable if their knees are also at an angle of approximately 90°.

The height of the footrests on the wheelchair should be set so that they support the legs and feet and, in turn, the underside of the thighs. This will reduce further pressure on the buttocks. If the footrests are too high or the seat too low, the user's knees will be higher than the hips so that pressure under the buttocks is increased.

If the footrests are too low, or the seat too high, the user's knees will be lower than the hips and pressure will build up under the thighs.

## Footrest angle

For users with long legs, some wheelchairs have footrests that are set out at a wider angle in front, so that the leg length can be accommodated without hindering activities such as kerb climbing.

## Footplate angle

The angle of some footplates (i.e. the flat plate at the end of the footrest on which the feet are placed) can sometimes be adjusted. Feet can be very strong

stimulators of muscle contractions of the whole body, and may cause total extension patterns or tremor spasms in the legs. This is a common problem experienced by users with MS (multiple sclerosis). By making the footrest/footplate angle less than 90° the user's feet are prevented from slipping forwards and down off the footplates. This also stretches the calf muscles and may inhibit extension patterns and spasms.

## Backrest height

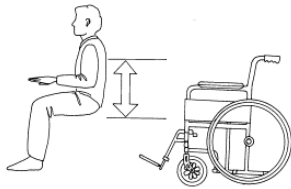

The upper body is stabilised by the support from the backrest, which should be high enough to stabilise the upper lumbar region. Above this level, the backrest height is a matter of individual need and/or personal preference.

Some users find that if they have a stable seating base they only need a backrest that comes halfway up their back but the disadvantage of a wheelchair with a small backrest is that pushing handles are often too low for an attendant to push comfortably. Some chairs have adjustable height push handles to overcome this problem.

## Backrest shape and angle

Most users will benefit from a backrest with an appropriately shaped lumbar area. This combined with a suitable backrest angle should provide support and balance for the upper body.

## Arm support

In theory, if someone has a stable seating base, then he/she should not need armrests. Armrests should not be used to help someone to stay in the chair - if this is the case, the user's seating base should be reassessed. A more sophisticated seating system may be necessary.

However, armrests provide useful rest and stabilising positions for users who tire rapidly and/or those whose upper limb or neck muscles are weak.

## Armrest height

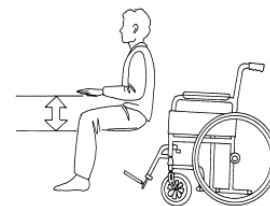

When armrests are properly adjusted they should support the user's forearms comfortably with the elbows at 90°. If they are too high, the user's shoulders will be hunched; if they are too low, the user will tend to slump to one side.

Armrests also provide an appropriate surface to push down on for users who stand up directly from their wheelchairs. However, they do make approaching tables and work surfaces difficult and often have to be removed for transfers.

Having sorted out the seating base on the wheelchair, the next thing to consider is the type and set up of the wheelbase. It is often thought that the weight and the material from which the wheelchair frame is made are the main factors which affect the manoeuvrability of the chair. In fact, it is the size and position of the wheels. These affect weight distribution, the rolling resistance and, therefore, the manoeuvrability and the amount of energy needed to propel the wheelchair.

### **A chair that is easy to manoeuvre**

The ability to back wheel balance has an important effect on manoeuvrability. To do this, the user balances the chair on the large rear wheels so that the front castors are lifted clear of the ground. This makes it easier for him/her to negotiate kerbs or avoid small obstacles such as an uneven surface or grids. 'Tippiness' is the term sometimes used to describe the ease with which the chair can achieve this balance.

Wheelchair users may be able to tip themselves back to find the balance point of any wheelchair, but the ease and safety with which they carry out this manoeuvre can vary considerably. The wheels on many standard wheelchairs tend to be set

quite far back so that more leverage, and therefore more energy, is needed to lift the castors off the ground. To find the balance point of a standard manual chair, the castors have to be lifted quite a long way off the ground so that the chair is leaning backwards at quite a dramatic angle! Active user wheelchairs have a multi-adjustable axle plate which allows the wheels to be set further forward under the user's body. This not only affects the leverage but also the distribution of weight over the wheels which, in turn, affects the 'tippiness' of the chair.

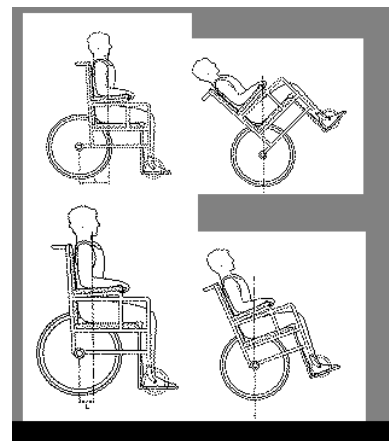

The higher the percentage of weight placed over the back wheels, the easier it is to lift the front castors off the ground. When the rear wheels of a wheelchair are moved forward, more weight is placed over them. Most standard wheelchairs have a weight distribution of 40:60 front to back wheel ratio, high performance wheelchairs have a 30:70 ratio.

This weight distribution also affects the rolling resistance, i.e. how much energy is

lost during pushing. This can be calculated by dividing the weight of the wheelchair by the area of the wheel which is in contact with the ground. The area of large rear wheels in contact with the ground is approximately twice as much as that of small front castor wheels (e.g.10mm: 5mm).

The average active user wheelchair weighs 12kg and the weight is distributed 30:70 front to back wheel. Calculated in the way described above, this type of wheelchair has a rolling resistance of 1.5.

If a standard, self-propelled wheelchair weighs 18kg, and if the weight is distributed 40:60 front to back, using the same calculation, the rolling resistance of this type of wheelchair is 2.5.

To achieve the minimum rolling resistance, therefore, as much as weight as possible needs to be placed over the larger back wheels without compromising stability.

## **An energy conserving chair**

Most standard self propelled wheelchairs have a 20-22in (51-56cm) rear wheel. High performance chairs usually have 24in(61cm) wheels and can have 26in (66cm) wheels. Therefore, using the previous calculation without taking into account any other influencing factor, high performance wheels are shown to have less rolling resistance since a larger area of the wheels is in contact with the ground,

making the chair easier to propel. The length of the wheelbase will also affect how much energy is needed to manoeuvre a chair. As the length is decreased, the turning circle is also shortened, with the result that less energy is needed to turn.

The position of the rear wheels also affects the amount of energy needed for propelling. If the wheels are set with their axles in a vertical line with the user's shoulders, the maximum push with the minimum amount of energy expenditure can be achieved. This also reduces the amount of wear and tear on the user's shoulder joints.

## **A chair that is easy to steer**

If a chair's rear wheels can be cambered (i.e. angled towards the chair at the top) the effort required to propel the chair across a slope in a straight line will be reduced dramatically. Anyone who regularly pushes outdoors and has to tackle pavements will therefore benefit from cambered wheels.

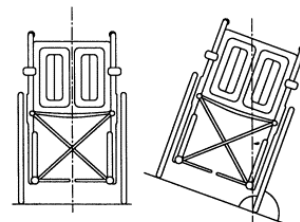

Cambered wheels also increase the ease with which the user can turn the

wheelchair. For everyday use, camber up to 5° is acceptable. Beyond this, the chair often becomes too wide so that going through narrow spaces, e.g. doorways and small bathrooms, becomes difficult.

People who use a wheelchair for sport may camber the wheels at more than 5° so that they can guide the chair with greater ease and accuracy.

### **A chair that is easy to transport**

Wheelchairs can be cumbersome and heavy to lift. Chairs with a cross bracing mechanism underneath the seat can be folded and made lighter by removing legrests and armrests. Rigid framed chairs too can be dismantled if the quick release wheels are removed, the backrest is folded down and the armrests are removed. (For more detailed information on carrying wheelchairs in a car, see DLF factsheet 'Out and about with your wheelchair'.)

### **A chair that is versatile/adaptable**

A person's body shape and size and his/her disabilities do not always remain static. As changes occur, the wheelchair requirements may also change. Standard wheelchairs can seldom be adapted and a different wheelchair would therefore be needed. Many active user wheelchairs have interchangeable component parts which make them more versatile and adaptable.

### **A chair that meets the carer's needs**

Many users of self-propelled wheelchairs are able to get themselves in and out of cars and buildings independently. However, some users may rely on someone else to load the wheelchair in and out of the car, or maybe to push them round in it, at least for part of the time.

If the person who is pushing the wheelchair is also the carer, it is especially important, once the user's needs have been met, to take into account as many of the carer's needs as possible. By reducing energy expenditure and increasing the chair's manoeuvrability and transportability, life will be made easier and the risk of back injury minimised. In addition, it should be possible for the carer to take the wheelchair user to a great many places that previously seemed either difficult to get to, or even inaccessible.

### **A chair that makes the user look good and feel confident**

A chair that is energy efficient and looks aesthetically pleasing will inspire confidence in the user.

# STANDARD SELF-PROPELLED WHEELCHAIRS

## FEATURES TO CONSIDER WHEN CHOOSING A NEW WHEELCHAIR

### Frame

#### Materials

Steel - strong, cheap but heavy. Aluminium - light and not too expensive. Folding frame - has a cross brace mechanism underneath the seat canvas which enables the wheelchair to be folded for easier storage and transportation. Less suitable for very active users as the flexibility of the frame demands that they use more energy.

Compact folding frame - folds up to a smaller size than the average folding frames so can be stored in small places.

Rigid frame - tends to be lighter and stronger than a folding frame but not so easy to transport. Most appropriate for active users and outdoor use as energy is not lost through movement of the frame.

#### Tipping levers

Enable an attendant to assist in kerb climbing. Anti-tip levers prevent a wheelchair tipping backwards beyond a certain point if no attendant is pushing the chair.

### Wheels

#### Tyres

Pneumatic - offer a better shock absorption than solid ones but may puncture.

Puncture-proof - filled with a jelly like substance; need less maintenance.

Solid - hard-wearing but can provide a rougher ride.

#### Detachable drive wheels

Useful to reduce the weight/size of the wheelchair for storing and transporting.

In general, the larger the wheels, the less effort is needed to propel.

#### Footrests

##### Fixed

Can get in the way when transferring.

##### Swing-away

Can be moved out of the way for transferring.

##### Detachable

Reduce size/weight of the wheelchair for storing and transporting.

## **Elevating**

For users who need to have their legs raised for longer periods, or to keep them straight.

## **Armrests**

### **Desk-style**

Allow access to work surface, but do not provide much arm support.

### **Adjustable height**

Can be adjusted to provide maximum support.

### **Fold-up-fold-down/swing-away**

May be more convenient for someone who needs to transfer sideways than detachable ones which can be mislaid.

## **Detachable**

Reduces size/weight of wheelchair for storing and transportation.

## **Backrest**

### **Dimensions**

Angle and height of backrest affect posture.

### **Folds backwards/forwards**

Useful when storing and transporting.

## **Pushing handles**

Many are an integral part of the backrest frame - others are an optional extra.

Adjustable height handles are a good idea if a person is assisting as they can be positioned to reduce backache during prolonged pushing.

## **Seat**

### **Dimensions**

It is vital that the user is accurately assessed for the correct seat size as this will determine posture and comfort. A cushion is essential.

### **Weight**

A lighter wheelchair is usually an advantage for both an active user and a carer.

## **SELF PROPELLED WHEELCHAIRS WITH SPECIAL FEATURES**

Sometimes standard wheelchairs do not provide adequate support or features to accommodate a person's disability. In such cases consider wheelchairs with special features.

### **Comfort wheelchairs**

This is the generic name given to a range of chairs which offer the user more

comfort and support. They are not as easy to handle and manoeuvre as other chairs. They have padded and contoured seats and backrests and may incorporate a range of features such as reclining backrest, tilt in space. They may have self-propelling rims or be attendant propelled.

## **WHEELCHAIRS FOR A PERSON WHO CAN USE ONLY ONE ARM**

### **One-arm-drive wheelchairs**

The left and right wheel axles are linked and a double handrim is located on one wheel to enable these wheelchairs to be propelled by using only one arm. Use of both handrims together will propel the wheelchair forward; used singly they will turn it to the left or the right. Many people find this type of wheelchair difficult to use. They tend to be heavier than standard wheelchairs and the user needs a great deal of strength and co-ordination. Negotiating slopes and hills is almost impossible. A brake extension lever is usually needed for the 'weaker' side and the user will need to stretch across to operate the lever.

### **Low-seat wheelchairs**

Low-seat wheelchairs enable their occupants to propel and steer using their feet. If the wheelchair is to be propelled solely by the feet, an attendant-only propelled type chair could be considered as these tend to be lighter than the self-propelled variety.

Only one footrest may be necessary if support is needed for a weaker leg. In this case, an extra support may have to be attached to the legrest to prevent the leg from slipping sideways. If both feet are to be used to propel the chair, neither footrest will be needed and the height of the seat should enable the user to place both feet firmly on the floor. Unfortunately, this type of propulsion will probably prevent the user from maintaining a good, stable seating posture. Compromises may have to be made. If the user tends to slide forwards out of the seat, then a trunk or pelvic support should be considered.

If a low seat chair is to be used mainly indoors, a castor chair, which often has a low seat and tends to be lighter than a standard wheelchair, could be considered.

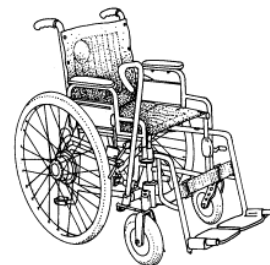

### **Lever-propelled wheelchairs**

Lever-propelled wheelchairs may have a hand lever on the left or right or both sides of the seat and users propel the wheelchairs with a push/pull action. The lever is connected to the front castors for steering. With the two levered chairs, the levers are pushed and pulled alternately

which enables the user to build up more speed. As is the case with the one-arm drive wheelchairs, some users find the lever-operated chairs difficult to use, and they demand quite a lot of strength and co-ordination on the part of the user. These chairs are difficult to propel over rough ground and up slopes. Brake lever extensions may be needed for the 'weaker' side.

## **WHEELCHAIRS FOR SOMEONE WITH A LOWER LIMB AMPUTATION**

If all or part of someone's leg has been removed, that person's centre of gravity will change. This may unbalance the wheelchair and there is a danger that it may tip backwards. To prevent this, the wheels must be set back. Chairs with this feature are available.

## **WHEELCHAIRS WITH A RECLINING BACKREST**

This feature would be needed by a user who:

- is unable to sit up because of weak muscles in the upper body, or a stiff spine or hip;
- needs to change position during the time spent in the wheelchair;
- has difficulty breathing;

- is receiving treatment that requires him or her to be in a reclining or semi-reclining position.

If the user needs to recline fully, check that the backrest can be so adjusted. Some models are only semi-reclining.

When contemplating a wheelchair with a reclining backrest, the user will need to consider the following.

### **Space**

- Check that there is enough room in the house to manoeuvre such a chair. Once the backrest is reclined and the legs elevated, it is very long.

### **Propulsion**

- Although some of these chairs have self-propelling wheels, their weight combined with the angle of backrest makes it impossible for users to propel them. Someone else will need to push them.
- Great care should be taken when wheeling the wheelchair outside in the reclined position. Negotiating kerbs in this position is virtually impossible.

### **Reclining mechanism**

- Check whether the mechanism can be operated by the user. Users will need to have good upper body strength as they will have to sit up before the

backrest can be moved. If the chair is attendant operated, can the mechanism be operated with the person in it?

## Legrests

Check whether the legrests can be operated by the user, who may wish to sit in an upright position with legs outstretched. Most have to be adjusted by someone else.

## Transporting in a car

It is virtually impossible to get reclining wheelchairs into a car because the high backrest does not fold and the chairs are very heavy to lift.

## WHEELCHAIRS WITH A TILT-IN-SPACE SEAT UNIT

A tilt-in-space seat unit in a chair enables the seat and backrest angles to remain fixed while both are tilted backwards. This type of unit may be appropriate for people with complex seating needs who have poor trunk and head control but advice about use of this feature should be sought from a wheelchair service.

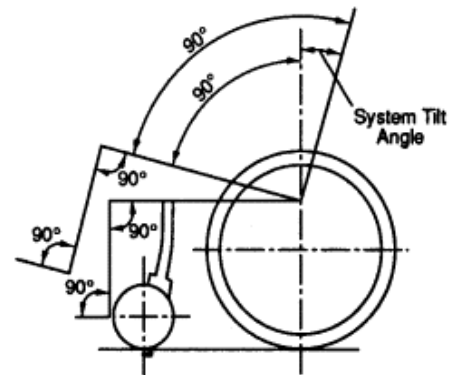

## WHEELCHAIRS WITH A STAND-UP MECHANISM

Wheelchairs with a stand-up mechanism can stabilise the user in the wheelchair so that the seat and backrest can flatten out, lifting the occupant to a near vertical position. The mechanism is usually controlled by the occupant.

These chairs enable users to be more independent as they can reach items at a higher level. Users find that these chairs give them a psychological boost as they make it possible for them to carry out activities on the same level as other people. They may also benefit the user's health, for instance by providing some pressure relief and improving circulation and the digestive system.

However, medical advice must be sought before trying one. People who have not stood for a long time may find that their legs are not strong enough to take their body weight. Fainting may be another risk.

The stand-up mechanism adds weight to the wheelchair so that it is harder to push and is more difficult to lift and transport.

## **WHEELCHAIRS WITH AN ELEVATING SEAT**

On some models the seat height alone can be adjusted to enable the user to reach higher levels. If the user needs help to stand, the front of the seat needs to be angled downwards so that the feet can be placed flat on the floor. A powered or mechanical mechanism will lift the back of the seat to an angle which will enable the user to stand up. Both self-propelling and attendant-only propelled versions are available. It must be noted that the seat-lifting mechanisms add weight to the wheelchair which will therefore be more difficult to propel. Units which replace the existing seat are available so that a wheelchair can be adapted.

## **MADE-TO-MEASURE WHEELCHAIRS**

Most wheelchairs are available with a range of options and these are configured to meet the user's needs. In some cases companies are able to adapt a wheelchair to meet special requirements, for example they can reinforce the frame, provide an extra wide or deep seat, a lower or higher seat, various backrest angles and extend the wheelbase.

# **GENERAL INFORMATION**

## **MAINTENANCE**

Although it is important to have wheelchairs regularly checked and serviced by an approved repairer, regular maintenance should also be carried out at home to keep it in good, safe working order. If the wheelchair has been obtained through the local wheelchair service, it should have been provided with a manual on how to care for it. If bought privately, this information should be sought from the manufacturer or retailer.

Before any major repairs are carried out at home, it is advisable to check that the terms of guarantee are not being invalidated.

The following is a maintenance guide for standard self-propelling wheelchairs. For additional details, contact the supplier.

### **Tyres**

- The pressure in the tyres should be checked weekly. Use a tyre pressure gauge and pump to the correct pressure, marked on the tyre side. Do not use an air line at a local garage.
- Check for punctures or weak/cracked tread. Change the tyre if necessary. A bicycle repair shop maybe able to assist if replacement tyres are needed.

The following should be checked every month:

## Wheels

- Check they are free spinning. If they wobble, loosen and take off the lock-nut and tighten the axle bolt.

## Spokes

- Check for loose or broken spokes. Tighten loose spokes so that they are the same tension as the others. Replace broken spokes.

## Hand rims

- Check for rough or sharp edges. Sand or file down if necessary.

## Brakes

- Check they are not coming loose. Reposition or tighten using screwdriver or spanner.
- Check that the brakes and tyres are making contact. If necessary, pump up tyres to correct pressure.
- Check that they are lubricated. Use silicon spray not oil or grease.

## Footrests

- Check that pivot parts are lubricated and that heel loops are securely anchored.

## Armrests/legrests

- Check for sharp edges.

## Push handle grips

- Check that they are secure.

## Frame

- Check for small dents or cracks - these can affect the frame strength.
- Dirt should be removed with a damp cloth. In winter, to prevent corrosion, check for, and regularly remove, salt which might have been picked up from the roads.

## Fork stem bearings

These should be checked every three months. Ensure that the axle bolt and nut allow the castor fork to swivel freely. If it is too loose, the wheelchair becomes difficult to steer.

## FURTHER READING

British Association of Wheelchair Distributors. *The good practice guide*. Compiled for the customer. BAWD, 1991.

British Standards Institution. *Methods of test for assessment of the ignitability of upholstered seating by smouldering and flaming ignition sources*, 2nd ed., BS

5852: 1990. BSI

British Standards Institution. *Wheelchair tests, Part 5: methods for determination of overall dimensions, mass and turning space*, BS 6935: Part 5:1988. BSI

British Healthcare Trades Association. Mobility Vehicles Section. *Code of practice and standard warranty conditions*. BHTA, 1993.

Directory for social change. *A guide to grants for individuals in need*. DSC. Published annually - should be available in your local library.

Griffiths, David and Wynne, David. *How to push a wheelchair*, 9th ed. Disabled Motorists Club West Midlands, 1991.

## USEFUL ORGANISATIONS

British Healthcare Trades Association – BHTA  
New Loom House, Suite 4.06 101  
Back Church Lane  
London E1 1LU  
Tel: 020 7702 2141  
Fax: 020 7680  
Email: [bhta@bhta.net](mailto:bhta@bhta.net)  
Website: [www.bhta.com](http://www.bhta.com)

British Red Cross (Head Office),  
44 Moorfields  
London  
EC2Y 9AL  
Tel: 0870 170 7000

Fax 020 7562 2000

Email: [information@redcross.org.uk](mailto:information@redcross.org.uk)

Website: [www.redcross.org](http://www.redcross.org).

ASSIST UK (formerly DLCC)

Redbank House,  
4 St Chad's Street  
Cheetham  
Manchester  
M8 8QA

Tel: 0870 770 2866

Textphone: 0870 770 5816

Fax: 0870 770 2867

Email: [general.info@assist-uk.org](mailto:general.info@assist-uk.org)

Website: [www.assist-uk.org](http://www.assist-uk.org)

Whizz-kidz

Elliot House

10-12 Allington Street

London SW1E 5EH

Tel: 020 7233 6600

Fax: 020 7233 6611

Wmail: [info@whizz-kidz.org.uk](mailto:info@whizz-kidz.org.uk)

Website: [www.whizz-kidz.org.uk](http://www.whizz-kidz.org.uk)

# Donation Form

We hope this factsheet has proven useful to you. If you would like to help the DLF continue to provide valuable information such as this, you may wish to consider making a small donation towards our work. As a charity, we rely on the generosity of the public to help us continue to help older and disabled people lead independent lives.

## Your Details

Name: \_\_\_\_\_

Address: \_\_\_\_\_

Postcode: \_\_\_\_\_

### Please accept my gift of:

£5     £10     £20     £30     £ \_\_\_\_\_ other

Please make cheques/postal order/ CAF Voucher payable to **Disabled Living Foundation**

Or charge my: Visa     CAF     Mastercard     Amex     Maestro

Card Number    /

Security Code     (last 3 digits located on back of card, or 4 digits for Amex)

Expiry Date    \_\_\_/\_\_\_    Valid From \_\_\_/\_\_\_    Issue No (Switch)

Name of cardholder    \_\_\_\_\_    Date: \_\_\_/\_\_\_/\_\_\_

Signature of cardholder    \_\_\_\_\_

*giftaid it*

I am a UK taxpayer and want the Disabled Living Foundation to treat all donations I have made since 6 April 2000 and all donations I make in the future as Gift Aid donations until I notify you otherwise.

NB: You must pay an amount of income tax and/or capital gains tax at least equal to the tax we reclaim on your donations in the tax year (currently 28p for every £1 you give)

**Please print out and return your completed form and cheque (if applicable) to:**

**Fundraising Department, Disabled Living Foundation,**

**380-384 Harrow Road, London W9 2HU**

**Thank You**

Please tick here if you would like to receive details on how you can help by making regular donations through your bank

Please tick here if you would prefer not to receive further communications from the DLF. Registered Charity No: 290069    A Company Limited by Guarantee Registered in England Number: 1837993