



# Choosing and fitting grab rails

---

DLF Factsheet

**© Disabled Living Foundation**  
**All rights reserved. No reproduction or transmission of this publication may be made without written permission.**  
**Inclusion (including any display advertising) does not indicate that any item has been recommended or tested.**  
**All information is provided without legal responsibility.**

**Disabled Living Foundation**  
**380-384 Harrow Road London W9 2HU**  
**Tel: (020) 7289 6111**  
**Fax: (020) 7266 2922**  
**Helpline: 0845 130 9177**  
**Textphone: 020 7432 8009**  
**Email: [advice@dlf.org](mailto:advice@dlf.org)**  
**Website: [www.dlf.org.uk](http://www.dlf.org.uk)**  
**Reg. Charity No: 290069**  
**VAT Reg. No: 226 9253 54**

---

# Contents

## Choosing and fitting grab rails

INTRODUCTION	4
WHERE TO GET HELP AND ADVICE	4
PROVISION OF RAILS	4
TYPES OF GRAB RAIL	5
FINISH OF RAIL	6
POSITIONING OF GRAB RAILS	6
FIXING OF GRAB RAILS	10
EARTHING OF GRAB RAILS	11
OTHER TYPES OF RAIL	12
USEFUL PUBLICATIONS	12
USEFUL ORGANISATIONS	12

---

## INTRODUCTION

The aim of this fact sheet is to provide first stop information on the types of grab rails available to help with specific difficulties, and details about their useful features and positioning.

Although primarily used in the bathroom and toilet, grab rails can be positioned anywhere in and around the home to provide support. Conveniently placed rails will provide help in four ways:

- to push or pull against when standing up
- to provide a steadying support while sitting down
- to provide a firm grip when transferring from one position to another
- for balance when standing, walking or dressing

Most are attached to the wall, although floor to ceiling rails are available. The type required will depend upon the situation and the hand or arm strength of the person. A combination of vertical and horizontal rails is often helpful.

For up-to-date product and supplier information, please contact our equipment helpline, open Monday to Friday from 10am to 4pm. Tel: 0845 130 9177 (calls charged at local rate) or if you use a Textphone 020 7432 8009.

Alternatively you can write to our letter enquiry service or contact us via e-mail at [advice@dlf.org.uk](mailto:advice@dlf.org.uk). To help us give you a concise and informative reply, please provide us with as much detail as possible including information on the difficulties you are having and any solutions you have considered, including equipment ideas.

## WHERE TO GET HELP AND ADVICE

Before making any decisions about buying equipment, or making alterations, it is advisable to contact a community occupational therapist (OT), based at the local social services/social work department, who will come and assess your daily living needs. He or she will advise on possible solutions and may be able to provide some items of equipment on loan and give advice on grants that may be available to help with the cost of any adaptations.

Information and advice on design issues is available from the Centre for Accessible Environments which keeps a database of architects, surveyors and similar professionals with experience of designing for disabled people, and has a number of useful publications and design sheets.

## PROVISION OF RAILS

Grab rails are generally regarded as daily living equipment, and may be provided by an occupational therapist at the social services department in England and Wales, the social work department in Scotland and the health and social services boards or trusts in Northern Ireland.

If you decide to buy equipment and gadgets privately, it is best to try them out first. If you can arrange a visit to one of the Disabled Living Centres, which will have a range of equipment on display, and from where you will be able to get advice and information on what may be most suitable for you.

For details of the one nearest to your, contact the Disabled Living Centres Council (see useful organisations).

## TYPES OF GRAB RAIL

When choosing a grab rail there are many factors to consider.

- Check that the rail is comfortable to hold and there is sufficient room between the rail and the wall to allow the person to secure a strong handgrip.
- It is recommended that there should be a space of about 4-6.5 cm between the wall and the rail.
- Ensure that the rail is comfortable to hold especially if the person has weak or painful hands. It is recommended that the rail should have a diameter of between 3-4.5 cm.
- Coloured rails that contrast with the wall colour are useful for people who have a visual impairment.

## STRAIGHT RAILS



These are wall-fixed rails which run in one direction only. They can be fixed in a horizontal or a vertical position, or at an incline.

## ANGLED RAILS

These are wall-fixed rails. The top portion is fixed in a vertical position and the lower, angled part acts as a forearm support whilst pulling up.



This enables the body weight to be distributed through his/her forearm which is useful for someone with painful hands or wrists.

## RIGHT ANGLED RAILS

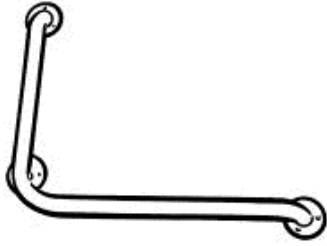

These are wall-fixed rails with a 90° bend to give both a horizontal and a vertical handhold. Useful in confined spaces.

## FLOOR TO CEILING RAILS

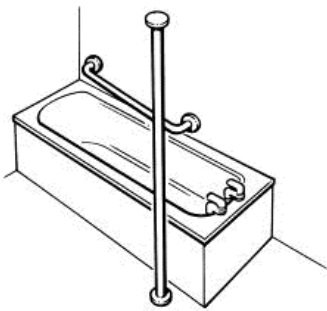

These are vertical rails which are attached to both the floor and the ceiling. They are particularly useful when positioned on the outer edge of the bath to provide support when turning round to step in or out.

## SYSTEM RAILS



These are rails which can be put together to provide support over a large

area, e.g. round a bathing area. They attach to the walls and the floor and can be cut to the required length with a hacksaw.

## FINISH OF RAIL

The finish of the rail may be important from an aesthetic point of view and also for the grip surface it provides.

### POLISHED/CHROME FINISH

This finish is attractive and hard wearing but can be quite slippery to hold, especially when hands are wet. The rails are usually supplied with earth bonding kits.

### EPOXY/PAINT/PLASTIC FINISH

This provides a warmer feel to rails, is hard wearing and will reduce the effects of condensation. Choice of colours allows for colour co-ordination of bathroom accessories.

### SLIP RESISTANT/ KNURLED/RIBBED FINISH

This is a moulded/coated textured surface which provides extra grip even when wet. This finish may be uncomfortable for those with sensitive hands.

## POSITIONING OF GRAB RAILS

Correct positioning of grab rails is important to ensure that they provide the support, where necessary, to perform specific tasks.

## GENERAL

### Horizontal rails

These help when pushing up from sitting and provide support when lowering, e.g. on to a toilet. Most people find it easier to push down on a rail rather than pull on one, so horizontal rails are more commonly used.

### Inclined rails

Rails that are fixed at a slight angle to the horizontal enable someone with weak or painful arms or wrists to support his/her forearm on the rail whilst pushing up, thus spreading the body weight over a larger area.

### Vertical rails

These help when pulling up into a standing position.

### Angled rails

For a person who needs a steady support (e.g. to stand from a bathboard to shower), a rail can be placed at an angle of 45° up and away from the user. This keeps the wrist in a neutral position. It is not necessary to lean far forward to grasp the rail at the lower end, and the hand can travel up the rail to maintain the support once the person is standing.

## FOR GETTING IN AND OUT OF THE BATH

The bather will often use one wall-fixed grab rail and the outer rim of the bath to push against to help him/her stand up.

The following specifications are recommended in *Designing for the Disabled* by Selwyn Goldsmith. However, they should be used only as a guide - other factors such as the height of the person should also be taken into account:

### Horizontal and inclined rails

- A rail 60 cm long can be fixed horizontally to the wall 10 cm above the bath rim. It should be positioned between 30 cm and 90 cm from the head end of the bath, (i.e. the non tap end).
- Alternatively a 1m straight rail can be fixed at an angle of 13° upwards towards the head end of the bath to provide an inclined support. The lower end should be positioned 2 cm above the bath rim and upper end 24 cm.

### Vertical rails

- A rail can be fixed vertically on the wall, 50 cm from the tap end of the bath, with its lower end 20 cm above the bath rim.
- Alternatively, a rail which attaches to both the floor and the ceiling on the outer edge of the bath may provide support when the person is turning round to step in or out. It is recommended that it should be sited 40 cm from the tap end of the

bath where it can be reached from a sitting position in the bath. However, its position could impede someone using a bath board who finds it difficult to bend his/her legs.

## Other types of support

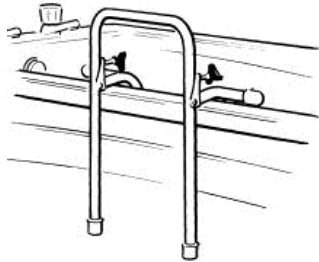

## Bath side rails

These clamp onto the side of the bath and can be adjusted to the thickness of the bath sides. A vertical loop projects above the sidewall. Rails that attach solely to the bath itself are not recommended, as great care needs to be taken to ensure that the fixing mechanism, usually a screw system, remains secure. This needs to be checked on a regular basis and tightened when necessary. Particular care must be taken when attaching one to a plastic bath, and there is a possibility that the surface may crack. Rails should be both bath- and floor-fixed for full stability.

## Cross bath rails

These fix to the wall behind the taps and rest on the bath rims. When sitting in the bath, the rail will be directly in front of

the person at about chest height. In this position it will provide stability whilst in the bath, but may not be in an ideal position to help the user to sit down or stand up from the base of the bath.

## Tap-fixed rails

These rails are not recommended as they clamp around the bath taps and are therefore only as strong as the tap fixtures. Taps are not designed to withstand a full body weight pulling against them. These rails fold down to rest on the bath rim and can be folded up against the wall when not required.

## GETTING UP AND DOWN FROM THE TOILET

For ambulant people it is best to have supports fixed on both sides of the toilet so that the person can use both arms.

The following specifications are recommended in *Designing for the Disabled* by Selwyn Goldsmith. However, they should be used only as a guide - other factors such as the height of the person should also be taken into account:

### Horizontal and inclined rails

- A rail of at least 40 cm long can be fixed to the wall at a height of 22.5 cm above the height of the toilet seat.
- Alternatively a rail at least 50 cm long can be fixed at an angle 15° downwards to provide an inclined support. Its front end should be positioned between 67 and 70 cm above floor height and at least 20 cm in front of the edge of the toilet pan.

- This type of rail might assist a person with painful wrist and hands.

## Vertical rails

- A rail at least 40 cm long can be fixed to the wall at a height between 100 cm and 140 cm above floor level. It should be fixed 30 cm in front of the edge of the toilet pan.
- Alternatively, an angled rail can be fitted with the vertical portion fixed to the wall, 30 cm in front of the toilet pan. This enables the person to support the weight of his arm whilst pulling with his/her hand on the vertical section.

## Angled rails

These rails are placed at an angle of 45° upwards and away from the user. The end of the rail nearest to the user should be just in front of their knee and should rise from elbow height.

## Other types of support Drop down rails



These rails are useful when there is no suitable wall on which a standard grab rail can be fixed, or where space is a problem. In areas where there is a wall on only one side of the toilet, they can

be used in combination with a fixed rail to provide support on both sides but can be folded up out of the way to allow access for a wheelchair user or helper.

Hinged rails may be wall-fixed (at the back of the toilet) or mounted on a floor-fixed console if the supporting wall is not strong enough. Some rails can be supplied with a support leg which rests down on the floor when the rail is horizontal, transferring some of the load from the wall to the floor.

## Wall to floor rails

These are static right-angled rails that attach to the wall behind the toilet and the floor in front of it. They are useful for providing support and stability where there is no adjacent wall.

## WC seats with frames



These are tubular frames, which are designed to provide horizontal support for pushing up from a toilet, or for steadying the body when lowering onto a toilet. The frame, which stands over the top of the toilet, can either be free standing or fixed to the floor. It is essential to fix it to the floor if the person has poor balance or co-ordination, or pushes down more heavily on one side than the other.

## GETTING IN AND OUT OF A SHOWER

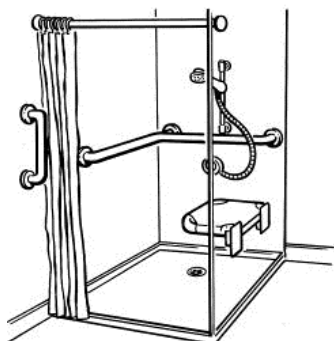

The following specifications are recommended in *Designing for the Disabled* by Selwyn Goldsmith. However, they should be used only as a guide - other factors such as the height of the person should also be taken into account:

### Horizontal rails

- A rail can be fixed on to the wall at the side of the shower seat, approximately 20 cm above the height of the seat. As well as being useful to help someone to stand up, it will allow wheelchair users to pull on it in order to transfer across onto the seat from a wheelchair.
- In addition it may be useful to have a horizontal rail fixed on the wall opposite the shower seat at a height of 1m from the ground.

### Vertical rails

- A rail at least 40 cm long can be fixed at the entrance to the shower compartment on the wall opposite the seat. It should be fixed between 90 cm and 130 cm above floor level.

However, the distance between the front of the seat and the rail must be less than 55 cm if it is to be used successfully.

## FIXING OF GRAB RAILS

Grab rails are only as strong as the wall to which they are fixed and the fixings that are used. Unfortunately many modern houses which were built as cost effective, thermally efficient buildings do not have internal walls that are ideal for the installation of wall fixtures such as support rails and shower seats.

You will need to ensure that you are using the correct type of fixing for the material of the wall.

### TRADITIONAL BRICK AND CONCRETE BLOCKS

- Good quality traditional masonry and bricks should cause no problems if the recommended fixtures and procedures are followed. A plasterboard or tiled surface should not effect the fixing, although ensure that the whole depth of the fixing is supported by the masonry.
- Most dense concrete blocks are strong enough to support rails. However, care should be taken as their composition may make it difficult to drill a straight hole through them.

### LIGHTWEIGHT AERATED AND HOLLOW BRICKS

- If the wall is made of lightweight, aerated and hollow brickwork, even the most appropriate fixings may not be able to

withstand the loads which can be suddenly applied to rails and hinged arm supports.

- The insides of the hollow blocks are often filled with a polystyrene type insulating material which will not provide enough support for fixtures screwed into it.
- similarly, aerated concrete blocks, which are often used in bathrooms and toilets as the waste pipes are carried through their cavities, are made of a very lightweight substance which limits their fixing support qualities. Supporting fixtures should be attached to this type of wall using specific wall-mounted support products.

## **PREFABRICATED PARTITIONS**

- Even if a partition or stud wall is physically strong and stable and has a suitable flat surface to take a grab rail, the addition of a backboard on the outside wall is advised when fixing a grab rail to it.
- This should be a flat, unknotted piece of wood, which is screwed into the vertical joining pieces of the partitions. The grab rails can then be attached to the board. Self-tapping screws should be used when attaching rails to metal stud partitioning.
- Particular care should be taken when attaching rails to domestic sandwich partitions, e.g. plasterboard with a hardboard facing.

## **EARTHING OF GRAB RAILS**

The Institute of Electrical Engineers has published regulations which aim to promote safety and reduce the risk of injury from electrical accidents. They require that any metal parts of a building which could become live should be earthed.

If you are installing a metal grab rail in a wet area such as the bathroom, you must ensure that there is no possibility that any metal part which may be touched by the person, including fixing screws, will come in contact with electric cabling. The following types of metal grab rails do not have to be earthed:

- metal rails which have a plastic or other non-conductive coating, and a snap-over cover plate providing an insulating layer over the wall-fixing screws;
- metal rails where the screws are fixed through plastic seats, and covered by a plastic cap, effectively isolating the screw from touching the rail;
- metal grab rails which are fixed to a non-conductive material, such as brick or timber, which definitely has no conductive parts running in it, e.g. metal pipes which could make contact with the rail via a fixing screw.

There is a small chance that metal pipes within the wall could become live by making contact with a faulty electrical appliance in another part of the building. If one of the

fixing screws of the rail is in contact with the pipe, the rail could become live.

If a metal grab rail does need earthing, you will need to attach an earth cable to the rail and run it to the earth terminal in the main consumer unit.

Detailed information on guidelines for installation of metal grab rails in the bath area are covered in the regulations for electrical installations or contact the Technical Officer at local housing authorities/departments.

## **OTHER TYPES OF RAIL STAIR OR CORRIDOR RAILS**

Long lengths of rail are available to provide support for people when walking up and down stairs or along corridors.

Most staircases have a handrail on one side although this may not extend to the full length of the staircase. Most DIY stores sell handrails which can be used to extend the existing handrail all the way up the staircase if it is required. Adding a handrail to the other side of the staircase will provide more support where needed.

Newel rails are designed to turn through 90 degrees around the newel post (the upright post of the stair banister). They provide a continuous grip as the user reaches the bottom or top of the stairs and turns the corner. They are available in a choice of colour and sizes.

## **USEFUL PUBLICATIONS**

Goldsmith S. (1984). Designing for the disabled. 3rd Ed. fully revised. RIBA Publications.

## **USEFUL ORGANISATIONS**

Centre for Accessible Environments (CAE)  
Nutmeg House  
60 Gainsford Street  
London SE1 2NY  
Tel/Textphone: 020 7357 8182  
Fax: 020 7357 8183  
Email: [cae@globalnet.co.uk](mailto:cae@globalnet.co.uk)  
Website: [www.cae.org.uk](http://www.cae.org.uk)

ASSIST UK (formerly DLCC)  
Redbank House  
4 St Chad's Street  
Manchester  
M8 8QA  
Tel: 0870 770 2866  
Textphone: 0870 770 5813  
Fax: 0870 770 2867  
Email: [general.info@assist-uk.org](mailto:general.info@assist-uk.org)  
Website: [www.assist-uk.org](http://www.assist-uk.org)

# Donation Form

We hope this factsheet has proven useful to you. If you would like to help the DLF continue to provide valuable information such as this, you may wish to consider making a small donation towards our work. As a charity, we rely on the generosity of the public to help us continue to help older and disabled people lead independent lives.

## Your Details

Name: \_\_\_\_\_

Address: \_\_\_\_\_

Postcode: \_\_\_\_\_

### Please accept my gift of:

£5     £10     £20     £30     £ \_\_\_\_\_ other

Please make cheques/postal order/ CAF Voucher payable to **Disabled Living Foundation**

Or charge my: Visa     CAF     Mastercard     Amex     Maestro

Card Number        /     /     /

Security Code           (last 3 digits located on back of card, or 4 digits for Amex)

Expiry Date    \_\_\_/\_\_\_    Valid From \_\_\_/\_\_\_    Issue No (Switch)

Name of cardholder    \_\_\_\_\_    Date: \_\_\_/\_\_\_/\_\_\_

Signature of cardholder    \_\_\_\_\_

*giftaid it*

I am a UK taxpayer and want the Disabled Living Foundation to treat all donations I have made since 6 April 2000 and all donations I make in the future as Gift Aid donations until I notify you otherwise.

NB: You must pay an amount of income tax and/or capital gains tax at least equal to the tax we reclaim on your donations in the tax year (currently 28p for every £1 you give)

**Please print out and return your completed form and cheque (if applicable) to:  
Fundraising Department, Disabled Living Foundation,  
380-384 Harrow Road, London W9 2HU**

**Thank You**

Please tick here if you would like to receive details on how you can help by making regular donations through your bank

Please tick here if you would prefer not to receive further communications from the DLF.

Registered Charity No: 290069    A Company Limited by Guarantee Registered in England Number: 1837993