



Choosing an active user wheelchair

DLF Factsheet

**© Disabled Living Foundation
All rights reserved. No reproduction or
transmission of this publication may be
made without written permission.
Inclusion (including any display
advertising) does not indicate that any
item has been recommended or tested.
All information is provided without legal
responsibility.**

**Disabled Living Foundation
380-384 Harrow Road London W9 2HU**

**Tel: (020) 7289 6111
Fax: (020) 7266 2922
Helpline: 0845 130 9177
Textphone: 020 7432 8009
Email: advice@dlf.org
Website: www.dlf.org.uk
Reg. Charity No: 290069
VAT Reg. No: 226 9253 54**

Contents

Choosing an active user wheelchair

INTRODUCTION	4
ACTIVE USER WHEELCHAIRS	12
SOURCES OF SUPPLY - WHO CAN HELP?	17
FURTHER READING	21
USEFUL ADDRESSES	21



INTRODUCTION

For people who spend most of their day in a wheelchair an active user chair is one which offers adjustability and manoeuvrability and can be set up to meet the specific needs of the user. These chairs provide the user with independence and mobility and have helped to dispel negative attitudes towards wheelchairs.

This type of chair is often regarded as sporty and suitable only for young, fit wheelchair users who play sport and can push for miles. Active user chairs meet these needs very well but in many ways they are as suitable for the older or possibly frailer user who is finding it increasingly difficult to propel a standard manual wheelchair.

Active user chairs are more flexible than the standard chairs and can be adjusted to meet the individual requirements of users so that he/she can achieve the maximum amount of mobility. They have quick release wheels, multiple axle positions and frames that are available in a wide variety of sizes.

Originally designed for sport, they are lighter than standard chairs and are therefore easier to propel and transport. Also, the large rear wheels can be brought forward to alter the weight distribution so that the user needs much less energy to propel the chair.

In addition, the above features make it much easier for someone else to push these chairs, so that they are being used increasingly as attendant-propelled chairs.

Remember that one wheelchair may not provide all the answers. Compromises may have to be made once the priorities of each need have been weighed up. Some users may require two different types of wheelchair, each for a different range of activities - one self-propelled wheelchair for everyday use and another for sports purposes; or a self-propelled wheelchair for use indoors for short distances, and a powered electric wheelchair for long distance outdoor use.

WHAT DOES THE USER NEED?

A stable seating base

All wheelchair users who propel themselves need a comfortable, stable seating base. They cannot be expected to propel efficiently if part, or all of their energy is being channelled into trying to sit up straight. Many users waste valuable energy either shifting and fidgeting in the chair to maintain a comfortable posture or constantly heaving themselves up as they slide forwards or sideways. It is important that users are able to save as much energy as possible so that, having propelled themselves from A to B, they still have enough energy to carry out whatever activity is necessary. For people with mild to moderate seating difficulties, the correct size and positioning of the wheelchair seat unit components may be all that is needed to provide them with a stable seating base. For wheelchair users who do not have the ability to sit unaided, and those who lose that ability, perhaps as the result of a progressive disabling condition, may need a wheelchair that is used in conjunction with a more sophisticated seating system.

A stable seating base can be achieved if the following factors are considered:

Seat size

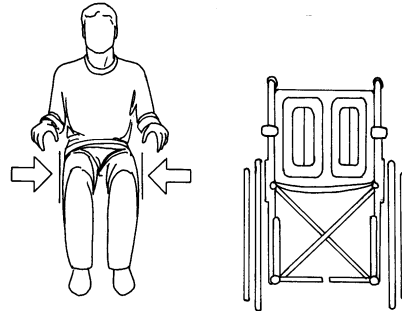

Maximum stability will be achieved if the body of the user fits comfortably into the chair seat. If the seat is too wide, the user may not sit symmetrically; if the seat is too narrow, there is a risk of pressure sores.

If the seat is too short, the full length of the thighs will not be supported and too much pressure will be transferred onto the buttocks.

If the seat is too long, a pressure area may develop behind the knee, and the user may not get adequate support from the backrest.

Active user chairs are often supplied with a range of seat depths.

Shape and angle of seat

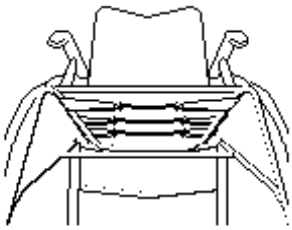

The seat needs to be level. A sagging wheelchair seat canvas will cause users to sit asymmetrically with their thighs and knees rolled together. This will cause undue pressure and shearing - the term used when the outer layer of skin is pulled in a certain direction while distorting and restricting the underlying blood vessels. This may lead to pressure sores.

The tension of the seat canvas on many active user wheelchairs can be adjusted to keep the seat level. If this adjustment cannot be made, a board straight onto the frame or integrated into a cushion can be used.

The stability of the pelvis is determined by the angle between the thighs and the trunk, which, in turn, affects the ability of the user to maintain a good-seated posture. An angle of 90° is considered best for most people undertaking daily activities. Using a contoured cushion or ramped seat, i.e. very slightly lower at the back to accommodate the shape of the buttocks, is the easiest way of achieving this.

Some wheelchair users sit with the seat sloping backwards and downwards and with the backrest slightly inclined forwards; this secures their pelvis more firmly and is called bucketing. It may, though, cause greater strain on the spine.

All wheelchair users should sit on a cushion which has been chosen at the same time as the wheelchair and fits the wheelchair seat. Full-time wheelchair users will probably need a pressure relief cushion; occasional users may only need one for comfort.

To fully stabilise the lower body, the foot support needs to be considered next.

Footrest length

If an angle of 90° between the hips and thighs of the user is achieved, most people will be comfortable if their knees are also at an angle of approximately 90°.

The footrests on the wheelchair should be set so that they support the legs and feet at a height where the undersides of the thighs are evenly supported along the length of the seat. If the footrests are too high or the seat too low, the knees of the user will be higher than the hips so that pressure under the buttocks is increased.

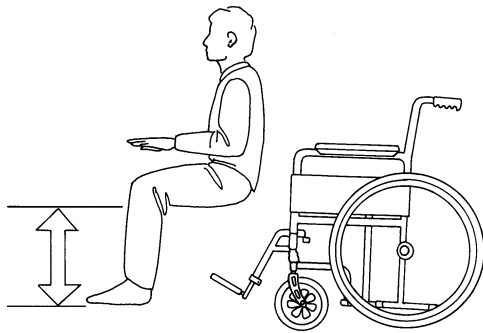

If the footrests are too low, or the seat too high, the knees of the user will be lower than the hips and pressure will build up under the thighs and behind the knees.

Footrest angle

For users with long legs, some wheelchairs have footrests that are set out at a wider angle in front, so that the leg length can be accommodated without hindering activities such as kerb climbing. Some active user wheelchairs have a choice of two or three footrests, each of which is set at a different angle.

Footplate angle

The angle of some footplates (i.e. the flat plate at the end of the footrest on which the feet are placed) can be adjusted on some chairs. Feet, which can be very strong stimulators of muscle contractions of the whole body, may cause extension patterns or tremor spasms in the legs. This is a common problem experienced by users with MS (multiple sclerosis). By setting the footrest/footplate angle at less than 90° the feet of the user can be prevented from slipping forwards and down off the footplates. This also stretches the calf muscles and may inhibit extension patterns and spasms.

Backrest height

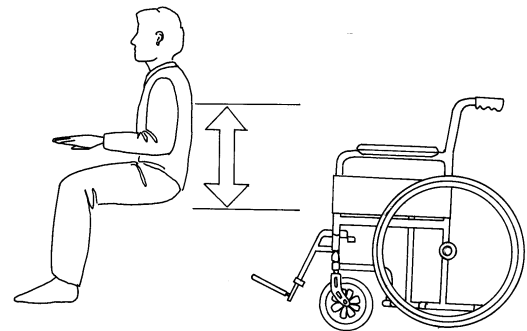

The backrest should be high enough to stabilise the upper lumbar region. Above this level the backrest height is a matter of individual need and/or personal preference.

Some users find that if they have a stable seating base they only need a backrest that comes halfway up their back. Although not as supportive as one that

extends to just below shoulder height, it enables the user to propel without restriction. This is a compromise that many active users find most comfortable.

The only disadvantage of a wheelchair with a lower backrest is that the pushing handles are often too low for the attendant to push comfortably. Some active user chairs have adjustable height or tall, removable push handles to overcome this problem.

Backrest shape and angle

Most users will benefit from a backrest with an appropriately shaped lumbar area. This, combined with a suitable backrest angle, provides support and balance for the upper body.

Many active user chairs are provided with backrest angle plates which make it possible for the backrest to be angled forwards by a few degrees to provide maximum support. These plates are useful, as the sitting posture of a wheelchair user will often change over a period of time.

Arm support

In theory, if a person has a stable seating base then he/she should not need armrests.

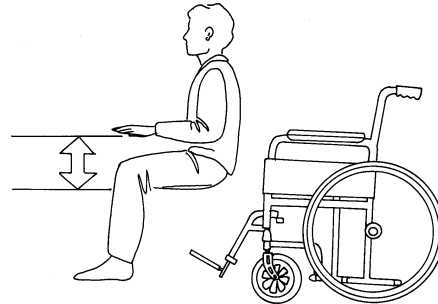

Armrests should not be used to help someone stay in the chair - if this is the case, the seating base of the user should be reassessed. A more sophisticated seating system may be necessary.

However, armrests provide useful rest and stabilising positions for users who tire rapidly and/or those who have weak upper limb and neck muscles.

Armrest height

When armrests are properly adjusted, they should support the forearms of the user comfortably with the elbows at 90°. If they are too high, the shoulders of the user will

be hunched; if they are too low, users will tend to slump to one side.

Armrests also provide an appropriate surface to push down on for users who stand up directly from their wheelchairs. However, they do make approaching tables and work surfaces difficult and often have to be removed for transfers.

Users whose wheelchairs do not have armrests should consider clothes guards made of stiffened material which protect clothes from some of the dirt from the wheels.

A stable seating position will not only benefit users physically, but also psychologically because, if they are sitting straight, their clothes will hang correctly so that they will look and feel better.

Once the seating base of the wheelchair has been sorted out, the next thing to consider is the type and set-up of the wheelbase. It is often thought that the weight and the material from which the wheelchair frame is made are the main factors which affect the manoeuvrability of the chair. In fact, it is the size and position of the wheels. These affect the weight distribution, the rolling resistance and, therefore, the manoeuvrability and the amount energy needed to propel the wheelchair.

A chair that is easy to manoeuvre

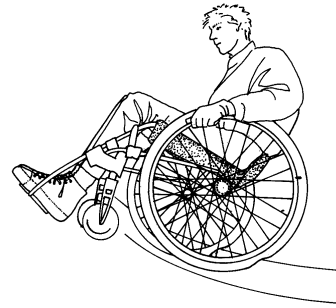

The ability to back wheel balance has an important effect on manoeuvrability. To do this, the user balances the chair on the large rear wheels so that the front castors are lifted clear off the ground. This makes it easier for him/her to negotiate kerbs or avoid small obstacles such as an uneven surface or grids.

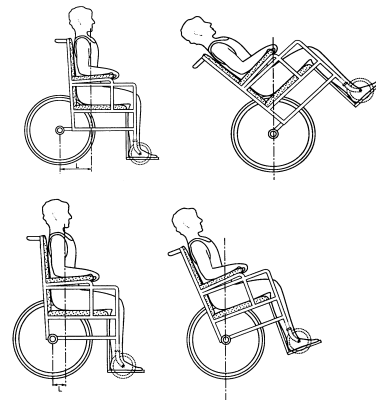

Tippiness is the term sometimes used to describe the ease with which the chair can be made to achieve this balance.

The position of the wheels affects the ease with which a chair can be tipped. The wheels on standard wheelchairs tend to be set quite far back so that more leverage, and therefore more energy, is needed to lift the castors off the ground.

To find the balance point of a standard manual chair, the castors have to be lifted quite a long way off the ground so that the chair is leaning backwards at quite a dramatic angle! Active user chairs wheelchairs have a multi-adjustable axle plate which allows the wheels to be set further forward under the body of the user. This not only affects the leverage, making it easier to lift the castors off the ground, but also the distribution of weight over the wheels, which, in turn, affects the tippiness of the chair. The higher the percentage of weight placed over the back wheels, the easier it is to lift the front castors off the ground. When the rear wheels of an active user chair are moved forward, more weight is placed over them. Standard wheelchairs have a weight distribution of 40:60 front to back wheel ratio, high performance wheelchairs have a 30:70 ratio.

This weight distribution also affects the rolling resistance, i.e. how much energy is lost during pushing. This can be calculated by dividing the weight of the wheelchair by the area of the wheel that is in contact with the ground. The area of large rear wheels in contact with the ground is approximately twice as much as that of small front castor wheels (e.g. 10mm:5mm).

The average active user wheelchair weighs 12kg and the weight is distributed 30:70 front to back wheel. Calculated in the way described above, this type of wheelchair has a rolling resistance of 1.5.

If a standard, self propelled wheelchair weighs 18kg, the weight is distributed 40:60 front to back so that the rolling resistance of this type of wheelchair is 2.5.

To achieve the minimum rolling resistance, therefore, as much weight as possible needs to be placed over the larger back wheels without compromising stability.

An energy conserving chair

Most standard self-propelled wheelchairs have a 20-22in (51-56cm) rear wheel. Active user chairs usually have 24in (61cm) wheels but can have ones of 26in (66cm). Therefore, using the above calculation without taking into account any other factors, active user wheels are shown to have less rolling resistance since a larger area of the wheels is in contact with the ground so that the chair is easier to propel.

The length of the wheelbase will also affect the amount of energy needed to manoeuvre a chair. Active user chairs with their wheels set further forward have a shorter wheelbase and therefore a shorter turning circle so that the user needs less energy to turn the chair.

The position of the rear wheels also affects the amount of energy needed for propelling. If the wheels are set with their axles in a vertical line with the shoulders of the user, maximum push with minimum effort can be achieved. This reduces the

amount of wear and tear on the shoulder joints of the user.

A chair that is easy to steer

If the rear wheels of a chair can be cambered (i.e. angled towards the chair at the top), this will reduce dramatically the effort required to propel a wheelchair across a slope in a straight line. Anyone who regularly pushes outdoors and has to tackle pavements will therefore benefit from cambered wheels.

Less effort is needed to keep the wheelchair in a straight line if its wheels are cambered, and the ease with which the user is able to turn the wheelchair is also increased. For everyday use, camber up to 5° is acceptable. Beyond this, the chair often becomes too wide so that going through narrow spaces, e.g. doorways and small bathrooms, becomes difficult.

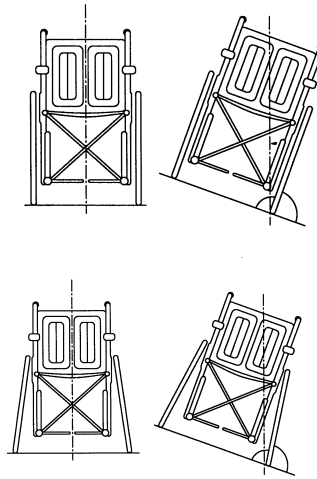

People who use a wheelchair for sport may camber the wheels at more than 5° so that they can guide the chair with greater ease and accuracy.

A chair that is easy to transport

Wheelchairs can be cumbersome and heavy to lift into a car. Chairs with a cross bracing mechanism underneath can be folded and made lighter if the leg rests and armrests and quick release wheels are removed, where possible. Rigid framed chairs can also be dismantled if the quick release wheels and armrests are removed and the backrest, etc are folded down. There are some rigid framed chairs designed with minimal metalwork beneath the seat. These are body-hugging frames which make it easier to bring the chair across the body when loading the chair into the passenger seat of a car.

A chair that is versatile/adaptable

The body shape and size of a person, as well as his/her disabilities, do not always remain static. As changes occur, the wheelchair requirements may also change. Active user wheelchairs have interchangeable component parts which make them more versatile and adaptable.

A chair that meets the needs of carers

Some users of self propelled wheelchairs are independent, and can get themselves in and out of cars and buildings. However, others may rely on someone else to load the wheelchair in and out of the car, or maybe to push them round in it, at least for part of the time.

If the person who is pushing the wheelchair is also the carer, it is especially important once the needs of the user have been met that as many as possible of the needs of the carer are also taken into account. By reducing energy expenditure and increasing the manoeuvrability and transportability of a chair, life will be made easier and the risk of back injury minimised. In addition, the carer may be able to take the wheelchair user to a great many places that had previously seemed either difficult to get to, or even inaccessible.

A chair that makes the user look good and feel confident

A chair that is energy efficient and looks aesthetically pleasing will inspire confidence in the user.



ACTIVE USER WHEELCHAIRS

WHAT FEATURES SHOULD YOU CONSIDER WHEN CHOOSING A NEW WHEELCHAIR?

Frame

Materials

Steel - strong, cheap but heavier than other materials. Easy to repair but may corrode if finish is damaged.

Aluminium magnesium alloy - lighter and not too expensive. An anodised finish helps to prevent corrosion and scratching.

Titanium and carbon fibre - strong, light but expensive. Does not corrode but may be difficult to repair.

Rigid frame

Tends to be lighter and stronger than a folding frame but may appear more difficult to transport as only the backrest folds. These frames are essential if the user is likely to take part in sports as they will not fold if hit from the side.

Folding frame

Enables wheelchair to be folded flat for easier storage and transportation. Not recommended for sports use.

Semi-rigid frame

These wheelchairs behave like rigid chairs (i.e. less energy is lost because the frame is flexible) but incorporate some kind of folding mechanism to make them easier to store and transport.

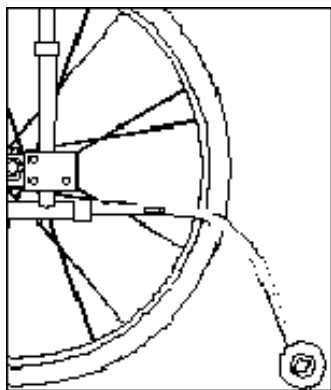

Anti-tip devices

Useful to give confidence to users getting to know the wheelchair, and for those learning to back wheel balance. However, they may inhibit users who use back wheel balancing to get up kerbs. Check whether the anti-tips can be removed.

Tipping levers

Enable another person to assist with kerb climbing - not usually needed as wheelchairs with a variable axle can be adjusted so that they tip back more easily.

Tyres

Castors

Pneumatic - offer better shock absorption than solid ones but may puncture.

Solid - hardwearing but can provide a rougher ride.

Sport - small and solid but not suitable for outside use.

Puncture-proof - filled with a jelly-like substance; need less maintenance.

Adjustable position

By adjusting the position of the castors, the wheelbase can be shortened so that the wheelchair becomes more manoeuvrable.

Large castors make propulsion more

difficult but make the wheelchair more manoeuvrable - a compromise must therefore be found!

Drive wheels

Multi-adjustable axle plate

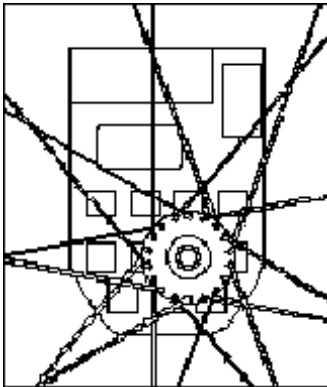

This plate enables the rear drive wheels to be positioned so that a compromise can be reached between manoeuvrability and stability. The chair will be most stable when the wheel is set in the bottom back position, and least stable when set in the top front position.

Quick release wheels

Useful to reduce the weight/size of the wheelchair when storing and transporting.

For those users who have restricted finger movements, a quad release mechanism can be obtained which makes the wheel easier to remove.

Composite (or mag) wheels

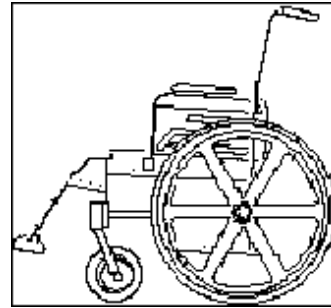

About six large plastic spokes which give the chair a sporty appearance and are easily cleaned. They should be used with a spoke guard as fingers can easily be trapped in fast moving vehicles.

Tyres

Pneumatic - offer better shock absorption but may puncture more easily.

Sports - these high pressure tyres have very little tread on their surface. They therefore provide less traction and rolling resistance, and so less energy is needed to propel the chair. Used mainly on sports wheelchairs, their features also make them useful for weak, independent users who tire too quickly when using ordinary tyres. However, they may prove an expensive option as they wear out quickly.

Camber

Ability to camber the rear wheels reduces the effort needed to propel a wheelchair across a slope in a straight line. Very important for anyone who pushes outside and therefore needs to tackle pavements.

Diameter

Drive wheels range in size from 18-26in (51-66cm). In general, the larger the wheels the less effort is needed to propel, but check whether they would hinder transferring especially on a short wheelbase.

Handrims

May vary in shape and finish. High friction finishes are available but may damage the hands if the wheelchair is stopped at high speeds. Capstan hand rims (with projections at oblique or right angles) may help a user who needs to propel with the palm of the hand.

Brakes

High mounted brakes

May cause obstruction when the user is transferring sideways. Also, fingers tend to catch in them when propelling. If the latter is a problem, look for brakes that retract when in the off position.

Low mounted brakes

User needs good balance to be able to reach down and operate them, but do not impede transfers.

Hill brakes

Allow forward propulsion but prevent rolling backwards on a hill.

Extension handles

Available for users unable to reach the operating lever, but may impede transfers.

Footrests

One-piece

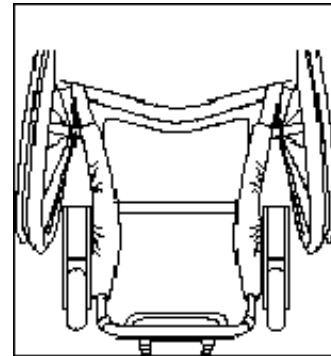

Add rigidity to the frame but may make transfers more difficult, especially when tapered relative to the seat width. Help to keep feet in position.

Flip-up

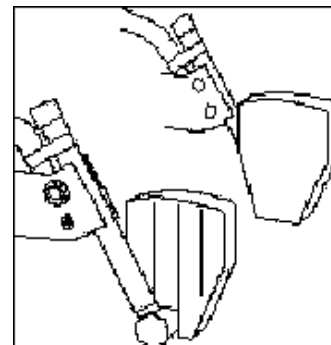

Enable user to stand within the frame when getting up from the wheelchair. They may be flip-ups alone on a rigid chair, or combined with swing-away fittings on a

folding chair.

Swing-away (out or under)

Can be moved out of the way for transferring. Usually detachable as well.

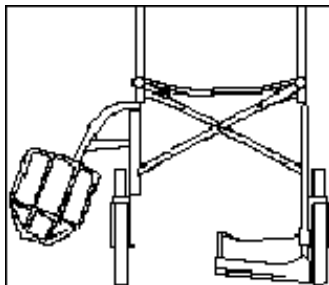

Detachable

Reduce the size/weight of the wheelchair for storing and transporting.

Elevating

For users who need to have their legs raised for long periods, or who need to keep them straight.

- Some wheelchairs now have one-piece footrests which swing back under the seat to ease transfer.
- Some models have the option of different, fixed angle footrests which can accommodate fixed deformities, tone reduction and extreme height while still enabling the footplates to clear the ground.

Armrests

Active users with a stable seating base may not want armrests that can restrict arm movement and so make propelling the chairs more difficult. A clothes guard may help to protect clothes from dirt and damage. They would need to be dropped down for transferring.

Desk-style

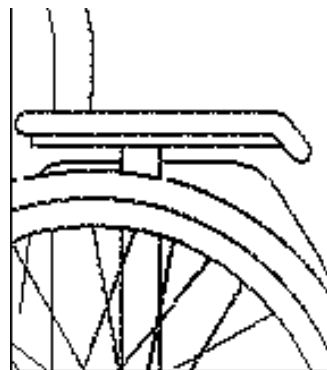

Allow access to work surfaces but do not provide support for people who need to push down on the armrest to stand up.

Tubular

Offer minimal support, look sporty and usually swing out of the way.

Adjustable height

Can be adjusted to provide maximum support.

Fold-up/fold-down/swing-away

May be more convenient for sideways transfers than detachable ones which can be mislaid.

Detachable

Reduce size/weight of wheelchair for storing and transportation.

Backrest

Dimensions

Angle and height of backrest affect posture.

Folds backwards/forwards

Useful when storing and transporting.

Pushing handles

Many are an integral part of the backrest frame - others are an optional extra.

Adjustable height

A good idea if a person is assisting as they can help reduce backache during prolonged pushing.

Seat

Dimensions

It is vital that the user is accurately assessed for the correct seat size, as this will determine posture and comfort.

Weight

A lighter wheelchair is usually an advantage for both an active user and for someone who is assisting.

SOURCES OF SUPPLY - WHO CAN HELP?

Wheelchairs and related equipment are provided through a number of different channels depending upon its primary purpose - especially whether it is for permanent loan or temporary use.

PERMANENT LOAN

Health and local authority provision

Most statutory provision of wheelchairs is carried out by, or through, the wheelchair service. This is part of the health authority or hospital trust and is organised on a district-wide basis. Often based at the local district hospital, it is able to provide wide range of wheelchairs and cushions.

Referral to the wheelchair service can be made by a range of professionals including therapists, nurses, and doctors. The prescription, however, needs to be undertaken by trained prescribers, i.e. they are accredited or recognised therapists or sometimes specialised nurses, hospital consultants, or GPs.

Apart from the basic criterion of limited walking ability, a number of other criteria are employed for obtaining a wheelchair. These however may vary between centres and at different times of the year.

A wide range of equipment is available. A standard range of manual wheelchairs, active user chairs and bespoke models are available through the wheelchair service. These are provided to meet the needs of individuals following certain criteria. Their availability may be affected by the state of the budget.

Since April 1996, powered indoor/outdoor wheelchairs have been provided to severely people who meet local eligibility criteria. They usually include the user being unable to propel a manual wheelchair, being able to benefit from an improved quality of life, and being able to control the chair safely. Powered attendant-propelled chairs can also be provided if it is hard for the carer to push the user out of doors.

The wheelchair service operates a voucher scheme. This is a cash equivalent based on the level of need added to by the user if they wish to purchase a more expensive chair.

Similarly, standard cushions, special cushions and special seating are available. These require varying levels of assessment and authorisation. Seating systems may be provided by special seating clinics.

EDUCATION SERVICE

Equipment that can be funded through the education service should be needed primarily for education and includes access devices, such as ramps, adaptations to school premises, wheelchairs for mobility at school, as well as other writing, speech and computer equipment.

It could be equipment for an individual, such as a wheelchair or cushion, or equipment for common use around a school, e.g. ramps, platform lifts and stairlifts. In theory, the equipment should be used for educational purposes only.

EMPLOYMENT SERVICE

Employment equipment and adaptations are defined as any equipment which is primarily for the purpose of meeting an employment need. This could include wheelchairs and cushions, ramps, short rise lifts, stairlifts etc.

Employment equipment and adaptations are provided through:

- The Disability Service Teams (DSTs) which operate within the Employment service (ES).
- Disability Employment Advisers (DEAs) who work from local job centres and who, as well as providing a wide range of advice and help to people who have particular difficulties in finding or keeping work because of a disability,

can also advise on how to obtain equipment for employment.

- Access to Work (AtW) Advisers have specialist knowledge of the AtW programme which helps disabled people and their employers overcome work related obstacles resulting from disability.

Help provided by the AtW scheme will depend on the needs of the individual and may take the form of special aids or equipment, adaptations to premises and equipment, communication support at interviews, assistance for fares to work, vehicle adaptations, personal reader service, support workers or any other help that may be relevant. The amount available is dependent on the help required.

For people who have been in a job less than six weeks or about to start work, AtW will cover 100% approved costs. For those who have been in their jobs for six weeks or more when they apply it will cover 80% costs up to £10,000 and all costs over £10,000.

Contact your Jobcentre or Job Centreplus to make an appointment with the DEA. The Job Centreplus Disability service team can put you in contact with the AtW Adviser.

PURCHASE OF EQUIPMENT

Private purchase

Private purchase might be preferred either because a person wishes to buy privately, or because the statutory services are unable to provide the item required.

Second-hand equipment

Some second-hand equipment, especially wheelchairs, scooters and buggies, can be bought through commercial suppliers. Although the equipment tends to be more expensive than it would be if bought from a private individual, usually it has been overhauled and may carry a guarantee of up to 12 months.

Many disability organisations publish journals which contain advertisements for second-hand equipment. DLF has a factsheet which lists these.

Funding from charitable sources

A directory entitled A guide to grants for individuals in need published by the Directory for Social Change contains the most complete list of the charities and organisations that will give grants and funding.

A specific charity that provides funding for children's wheelchairs is called Whizz-kidz.

SELECTING THE APPROPRIATE EQUIPMENT

Before buying, try to see and try out the equipment. There are about 40 Disabled Living Centres around the country which have a wide range of equipment on display. All can give advice and information on wheelchairs and related equipment. For details of your nearest centre contact:

Disabled Living Centres Council Redbank
House 4 St Chads Street Manchester M8
8QA Tel: 0161 834 1044 Textphone: 0161
834 1004 Fax: 0161 835 3591 Email:
dlcc@dlcc.demon.co.uk Website:
www.dlcc.demon.co.uk

Wheelchairs can be bought through the major manufacturers and local suppliers. It is best to try them out in a home setting to ensure that there are no hidden problems such as narrow doors or impassable steps.

Check whether the supplier belongs to the British Healthcare Trades Association - Wheelchair Distributors section. The association produces a code of good practice to which their members are expected to conform. Before purchase, the following should be checked:

- what is the delivery time?
- will the wheelchair arrive readily assembled?
- what guarantee is available?

- what after-care service is offered?
- how much is the call out charge?
- will spare parts be brought to the home?
- if the chair has to be taken away for repairs will a loan chair be offered?
- does the manufacturer offer insurance schemes?

SHORT TERM LOAN/HIRE OF WHEELCHAIRS

Statutory provision

If the wheelchair is needed only temporarily, a standard issue chair may be supplied through a number of channels. Only manual wheelchairs are provided on temporary loan. It is highly unlikely that a high performance wheelchair could be available through any of these channels. Three months is probably the average maximum loan period and the chairs are usually loaned free of charge. They may be obtained through the following sources:

- hospital loan via: hospital in-patient loan; hospital discharge wheelchair loan; hospital wheelchair pools;
- community nursing services;
- district wheelchair service

Voluntary organisation provision

Organisation such as the Red Cross sometimes loan standard manual wheelchairs on a temporary basis from local branches. The deposit and hire charges may vary.

Private hire

A number of private hire firms make daily/weekly/monthly hire charges which may vary in amount and in the conditions attached.



FURTHER READING

British Standards Institution. Specification for folding wheelchairs for adults. BS 5568:1978. BSI.

British Association of Wheelchair Distributors. The good practice guide. Compiled for the customer. BAWD, 1991.

British Standards Institution. Designation of types of wheelchair. BS 6936:1988. BSI.

British Standards Institution. Methods of test for assessment of the ignitability of upholstered seating by smouldering and flaming ignition sources. 2nd ed., BS 5852: 1990. BSI.

British Standards Institution. Wheelchair tests, Part 5: methods for determination of overall dimensions, mass and turning

space. BS 6935:Part 5:1988. BSI.

British Surgical Trades Association, Mobility Vehicles Section. Code of practice and standard warranty conditions. BSTA, 1993.

Cochrane, G M ed. Wheelchairs. 7th ed. Equipment for disabled people. Disability Information Trust, 1993. ISBN: 0-946112-24-X

Griffiths, David and Wynne, David. How to push a wheelchair. 9th ed. Disabled Motorist's Club West Midlands, 1991.

Male, Judith and Massie, Bert. Choosing a wheelchair. 2nd ed. Royal Association for Disability and Rehabilitation, 1990.

Mandelstam, Michael. Equipment for disability: a guide to provision. Disabled Living Foundation, 1991. (Available from DLF)

Mandelstam, Michael. How to get equipment for disability. 3rd ed. Jessica Kingsley Publishers, 1993.



USEFUL ADDRESSES

British Healthcare Trades Association – BHTA New Loom House Suite 4.06 101 Church Lane London E11UE Tel: 0207702 2141 Fax: 020 7680 4048 Email: bhta@bhta.com Webpage: www.bhta.com

British Red Cross UK Office 44 Moorfields
London EC2Y 9AA Tel: 0870 170 7000
Fax: 020 7562 2000
Minicom: 020 7235 3159 Email:
information@redcross.org.uk Webpage:
www.redcross.org.uk

ASSIST UK (DLCC)

Redbank House
4 St Chads Street
Manchester M8 8QA
Tel: 0870 770 2866
Fax: 0870 770 2867
Textphone : 0870 770 5813
Email: general.info@assist-uk.org
Webpage: www.assist-uk.org

RADAR (Royal Association for Disability and
Rehabilitation) 12 City Forum 250 City Road
London EC1V 8AF Tel: 020 7250
3222 Fax: 020 7250 0212 Email:
radar@radar.org.uk Webpage:
www.radar.org.uk

Whizz-Kidz Elliot House 10-12 Allington
Street London SW1E 5EH Tel: 20 7233 6600
Fax: 020 7233 6611
Email: info@whizz-kids.org.uk
Webpage: www.whizz-kids.org.uk

Donation Form

We hope this factsheet has proven useful to you. If you would like to help the DLF continue to provide valuable information such as this, you may wish to consider making a small donation towards our work. As a charity, we rely on the generosity of the public to help us continue to help older and disabled people lead independent lives.

Your Details

Name: _____

Address: _____

Postcode: _____

Please accept my gift of:

£5 £10 £20 £30 £ _____ other

Please make cheques/postal order/ CAF Voucher payable to **Disabled Living Foundation**

If you would like to make a credit card donation, please call our Fundraising Department on **020 7289 6111 (ext: 254)**, or alternatively visit our website at **www.dlf.org.uk**

giftaid it

Tick here if you are a UK taxpayer and would like the Disabled Living Foundation to reclaim the tax on all donations you have made for the 6 years prior to this year, (but no earlier than 6th April 2000) and on any future donations you make at no additional cost to yourself, until you notify us otherwise.

giftaid it

I am a UK taxpayer and want the Disabled Living Foundation to treat all donations I have made since 6 April 2000 and all donations I make in the future as Gift Aid donations until I notify you otherwise.

NB: You must pay an amount of income tax and/or capital gains tax at least equal to the tax we reclaim on your donations in the tax year (currently 28p for every £1 you give)

Please print out and return your completed form and cheque (if applicable) to:

**Fundraising Department, Disabled Living Foundation,
380-384 Harrow Road, London W9 2HU**

Thank You

- Please tick here if you would like to receive details on how you can help by making regular donations through your bank.
- Please tick here if you would prefer not to receive further communications from the DLF.